



Series 150 and 157

(Mercury Switch)



Series 150S and 157S

(Snap Switch, All Models except 157S-RB-P)

Low Water Cut-Off/Pump Controllers

For Steam Boilers and Other Level Control Applications

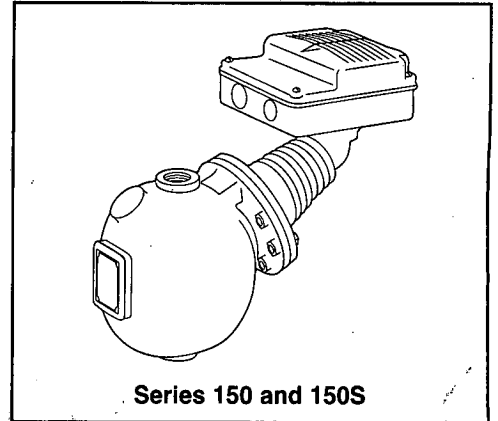

Series 150 and 150S

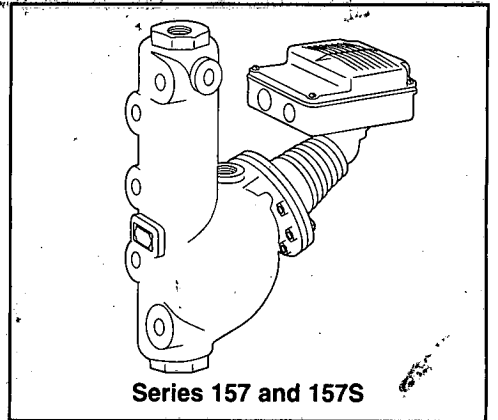

Series 157 and 157S

Typical Applications:

- Primary or secondary pump controller/ low water fuel cut-off for steam boilers
- Motorized valve controller
- Low water cut-off
- High water cut-off
- Alarm actuator

⚠ WARNING

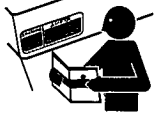

- Before using this product read and understand instructions.
- Save these instructions for future reference



- All work must be performed by qualified personnel trained in the proper application, installation, and maintenance of plumbing, steam, and electrical equipment and/or systems in accordance with all applicable codes and ordinances.



- To prevent serious burns, the boiler must be cooled to 80°F (27°C) and the pressure must be 0 psi (0 bar) before servicing.
- To prevent electrical shock, turn off the electrical power before making electrical connections.



- This low water cut-off must be installed in series with all other limit and operating controls installed on the boiler. After installation, check for proper operation of all of the limit and operating controls, before leaving the site.



- To prevent serious personal injury from steam blow down, connect a drain pipe to the control opening to avoid exposure to steam discharge.
- To prevent a fire, do not use this low water cut-off to switch currents over 7.4A, 1/3 Hp at 120 VAC or 3.7A, 1/3 Hp at 240 VAC, unless a starter or relay is used in conjunction with it.

Failure to follow this warning could cause property damage, personal injury or death.

OPERATION

Maximum Pressure: 150 psi (10.5 kg/cm²)

Electrical Ratings

Voltage	Pump or Motorized Valve Circuit Rating (Amperes)		Pilot Duty
	Full Load	Locked Rotor	
120 VAC	7.4	44.4	345 VA at 120 or 240 VAC
240 VAC	3.7	22.2	

Alarm Circuit Rating	
Voltage	Amps
120 VAC	1
240 VAC	1/2

Motor Horsepower	
Voltage	Hp
120 VAC	1/3
240 VAC	1/3

Settings and Differential Pressures

Values are $\pm 1/8$ " (3.2mm).

Series 150/157 and 150S/157S

Pressure	Setting	Approximate Distance Above Cast Line In. (mm)	Differential In. (mm)
0 psi (0 kg/cm ²)	Pump Off	15/16 (24)	5/16 (8)
	Pump On	5/8 (16)	
	Burner On	5/8 (16)	3/8 (16)
	Burner Off	1/4 (6.4)	
150 psi (10.5 kg/cm ²)	Pump Off	13/8 (41)	3/4 (19)
	Pump On	5/8 (16)	
	Burner On	7/8 (22)	7/8 (22)
	Burner Off	0 (0)	

150 psi (10.5 kg/cm²) Levels

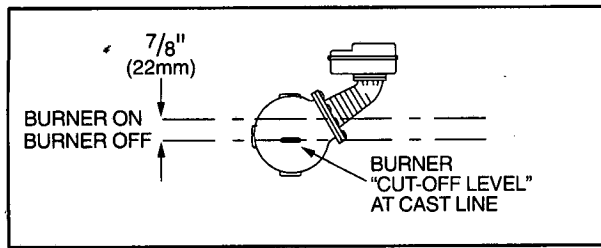
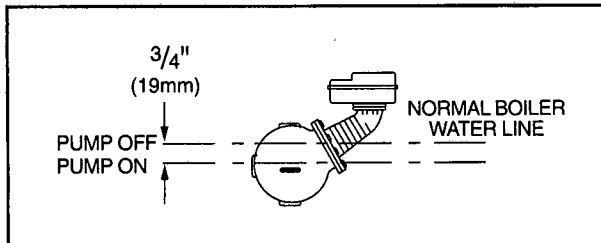
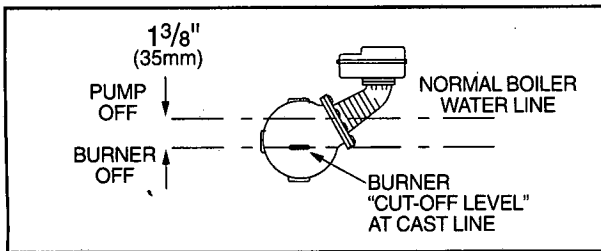

Models 150-MD/157-MD and 150S-MD/157S-MD

Pressure	Setting	Approximate Distance Above Cast Line In. (mm)	Differential In. (mm)
0 psi (0 kg/cm ²)	Pump Off	15/16 (24)	3/8 (16)
	Pump On	9/16 (14)	
	Burner Off	0 (0)	N/A
150 psi (10.5 kg/cm ²)	Pump Off	17/16 (37)	3/4 (19)
	Pump On	11/16 (17)	
	Burner Off	- 3/8 (-16)	N/A

150 psi (10.5 kg/cm²) Levels

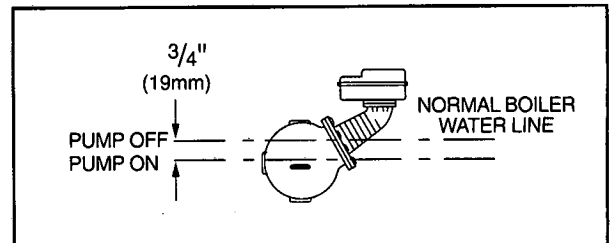
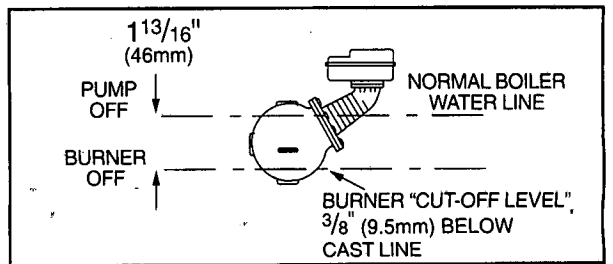

Settings and Differential Pressures (continued)

Values are $\pm 1/8"$ (3.2mm).

Models 158 and 158S

Pressure	Setting	Approximate Distance Above Cast Line In. (mm)	Differential In. (mm)
0 psi (0 kg/cm ²)	Motorized Valve Closed	15/16 (24)	5/16 (8)
	Motorized Valve Open	5/8 (16)	
	Burner On	5/8 (16)	3/8 (16)
	Burner Off	1/4 (6.4)	
150 psi (10.5 kg/cm ²)	Motorized Valve Closed	1 3/8 (41)	3/4 (19)
	Motorized Valve Open	5/8 (16)	
	Burner On	7/8 (22)	7/8 (22)
	Burner Off	0 (0)	

150 psi (10.5 kg/cm²) Levels

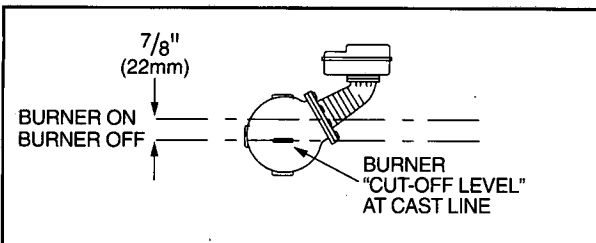
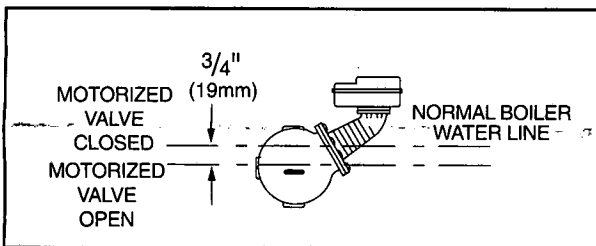
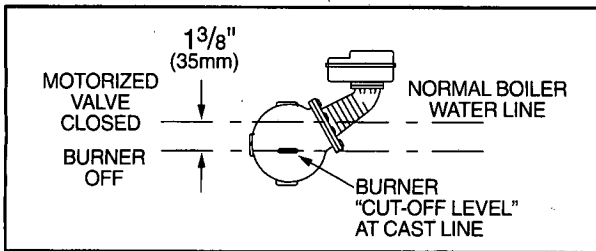

Note: Due to the slower operation of some motorized valves, complete valve opening or closing will occur at slightly different levels than indicated above.

Models 159 and 159S

Pressure	Setting	Approximate Distance Above Cast Line In. (mm)	Differential In. (mm)
0 psi (0 kg/cm ²)	Pump #1 Off	15/16 (24)	5/16 (8)
	Pump #1 On	5/8 (16)	
	Pump #2 Off	5/8 (16)	3/8 (16)
	Pump #2 On	1/4 (6.4)	
150 psi (10.5 kg/cm ²)	Pump #1 Off	1 3/8 (41)	3/4 (19)
	Pump #1 On	5/8 (16)	
	Pump #2 Off	7/8 (22)	7/8 (22)
	Pump #2 On	0 (0)	

150 psi (10.5 kg/cm²) Levels

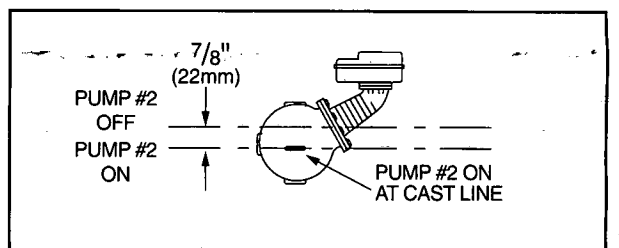
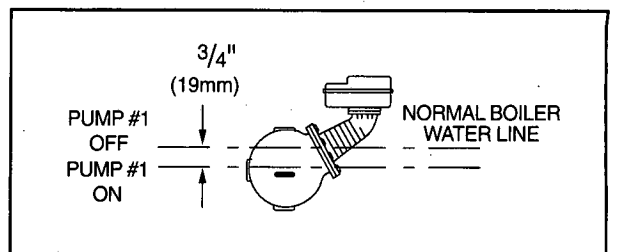
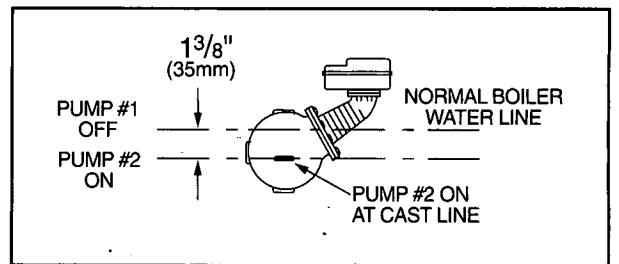

INSTALLATION –

TOOLS NEEDED:

Two (2) pipe wrenches, one (1) flathead screw driver, and pipe sealing compound.

IMPORTANT: Follow the boiler manufacturer's instructions along with all applicable codes and ordinances for piping, blow down valve and water gauge glass requirements.

STEP 1 - Determine the Elevation at Which the Low Water Cut-Off/Pump Controller Must be Installed

If the control will be the **primary low water fuel cut-off**, size the steam (top) and water (bottom) equalizing pipe lengths so that the horizontal cast line on the body is **1 3/8" (35mm) below the boiler's normal water level, but not lower than the lowest, safe permissible water level, as determined by the boiler manufacturer.**

OR

If the control will be the **secondary low water fuel cut-off**, size the steam (top) and water (bottom) equalizing pipe lengths so that the horizontal cast line on the body is **at or above, the lowest, safe permissible water level, as determined by the boiler manufacturer.**

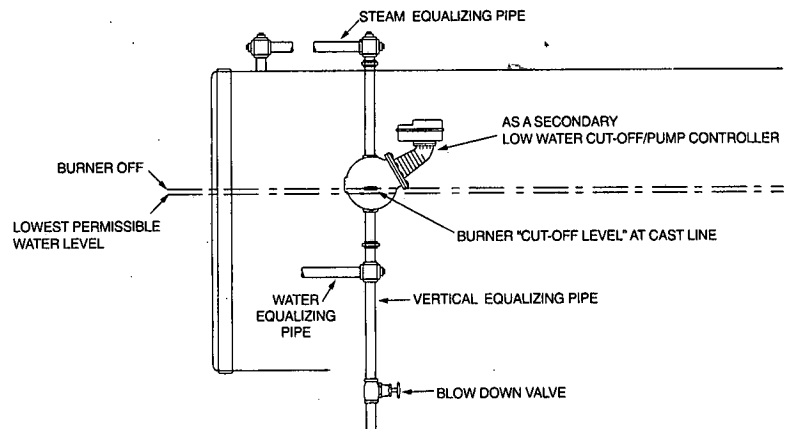
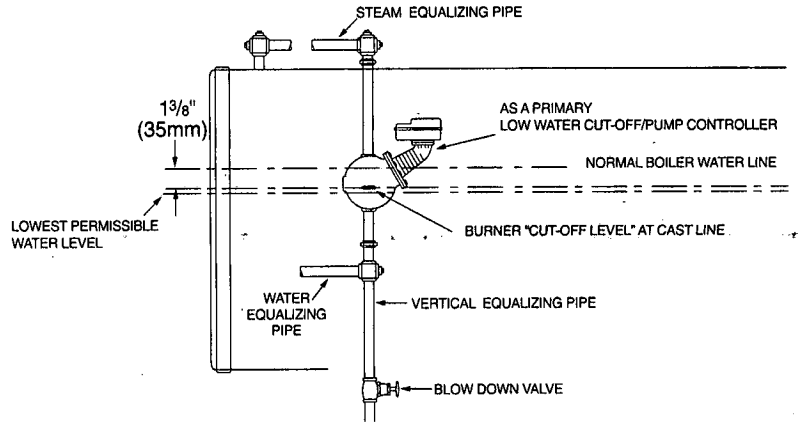

STEP 2 - Installing the Low Water Cut-Off

- Using a pipe wrench, unscrew the plastic float blocking plug (A) from the low water cut-off body (B).

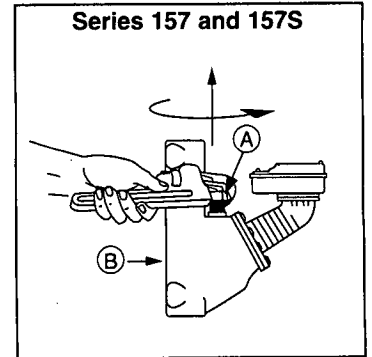
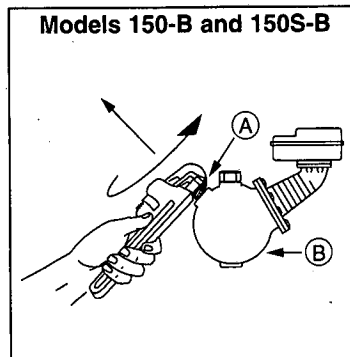
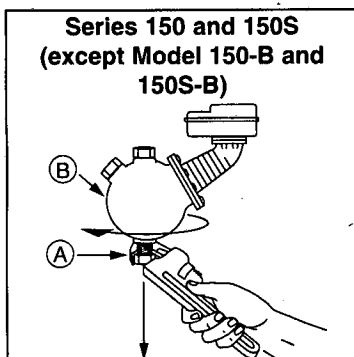

b. For Models 150-B and 150S-B and Series 157 and 157S (For all other models, proceed to Step 3).

Screw the $\frac{3}{4}$ " NPT steel plug (C) (provided) in tapping (A).

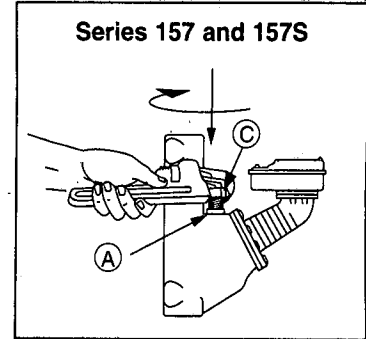
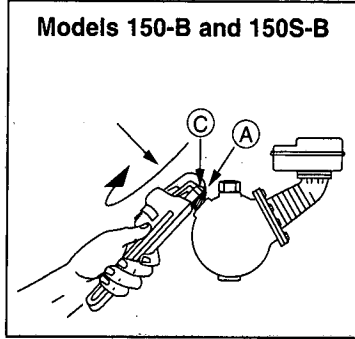

c. Mount and pipe the low water cut-off (D) on a vertical equalizing pipe (E) at the required elevation level, as determined in Step 1.

Install a full ported blow down valve (G) directly below the lower cross of the water equalizing pipe (F).

Note: 1" NPT tapings are provided, with the exception of some 157 and 157S models which are $1\frac{1}{4}$ " NPT.

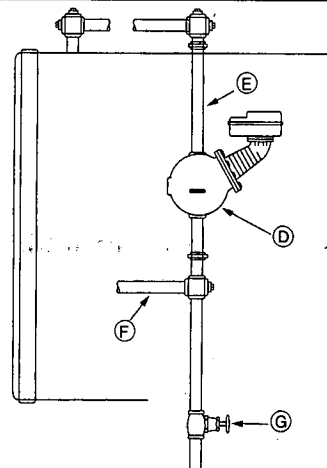

STEP 3 - Installing a Water Gauge Glass (Required on all steam boilers)

a. Install a water column (H) (not included with product) for all models except Series 157 and 157S (with integral water column).

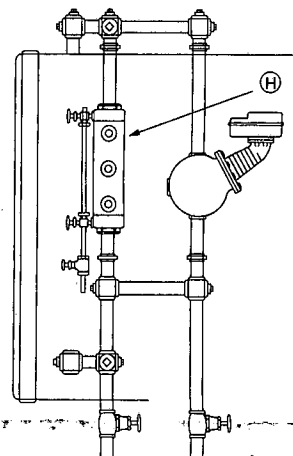

b. Install a water gauge glass (J).
Note: Gauge glass and tri-cocks not included with product.

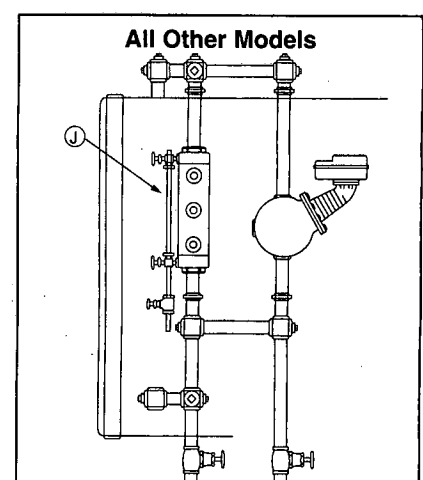
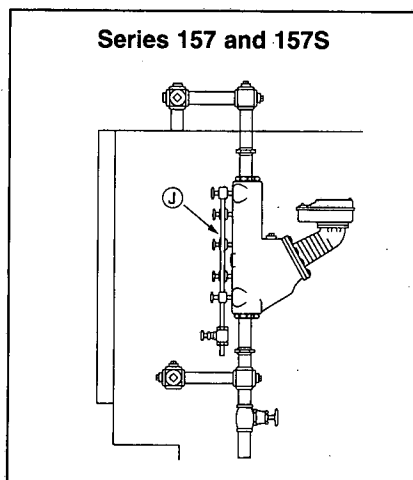

STEP 4 - Electrical Wiring

WARNING



- To prevent electrical shock, turn off the electrical power before making electrical connections.
- This low water cut-off must be installed in series with all other limit and operating controls installed on the boiler. After installation, check for proper operation of all of the limit and operating controls, before leaving the site.
- Modification of the switch assembly before or after installation could cause damage to the boiler and/or boiler system.



Failure to follow this warning could cause electrical shock, an explosion and/or a fire, which could result in property damage, personal injury or death.

Switch Operation

For all Models except 158/158S and 159/159S

Boiler feed pump off,
burner on, alarm off.

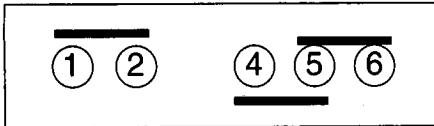

Boiler feed pump on,
burner on, alarm off.

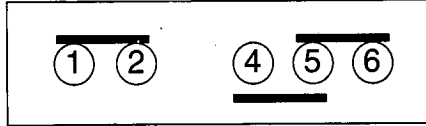

Boiler feed pump on,
burner off, alarm on.

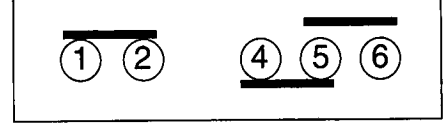

For Models 158 and 158S

Motorized valve closed,
burner on, alarm off.

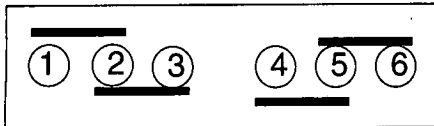

Motorized valve open,
burner on, alarm off.

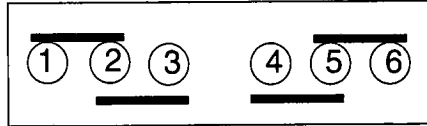

Motorized valve open,
burner off, alarm on.

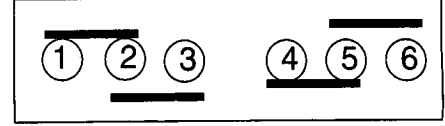

For Models 159 and 159S

Pump #1 off,
pump #2 off.

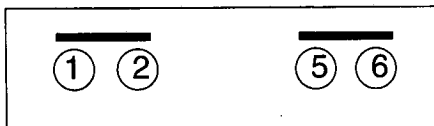

Pump #1 on,
pump #2 off.



Pump #1 on,
pump #2 on.

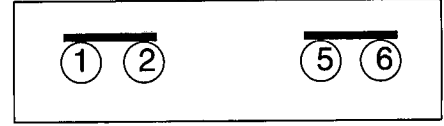

- a. Using a flathead screwdriver, remove the junction box cover (K).

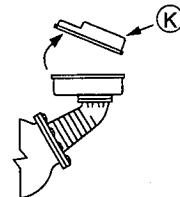

b. Following the appropriate wiring diagram; (refer to page 9) based on your application requirements, and using BX armored cable or Thinwall electrical metal tubing connector fittings, make electrical connections to the junction box (L).

IMPORTANT: There must be a minimum space of 1/2" (13mm) between connector fittings and electrical live metal parts.

Snap Switches (Series 150S and 157S)

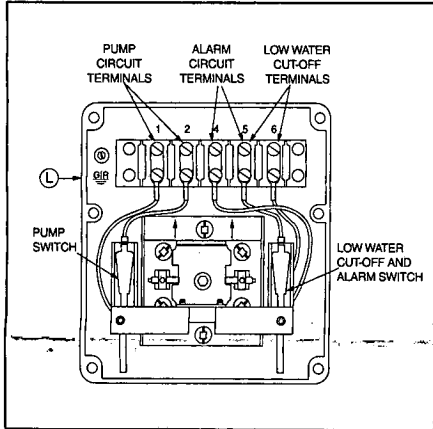

**Automatic Reset
(All models except 158S and 159S)**

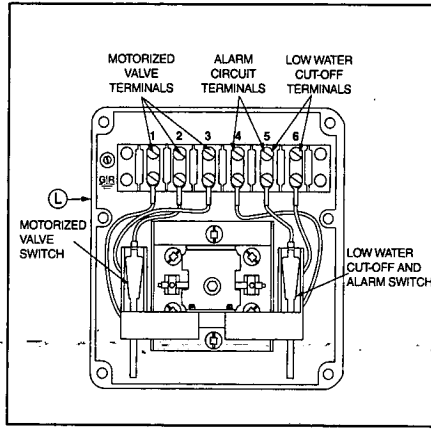

**Automatic Reset
Model 158S**

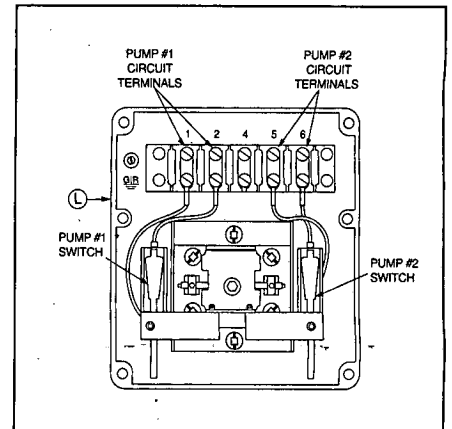

**Automatic Reset
Model 159S**

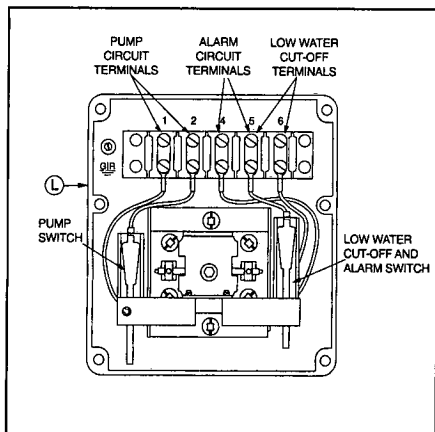

**Manual Reset
(All models except 158S)**

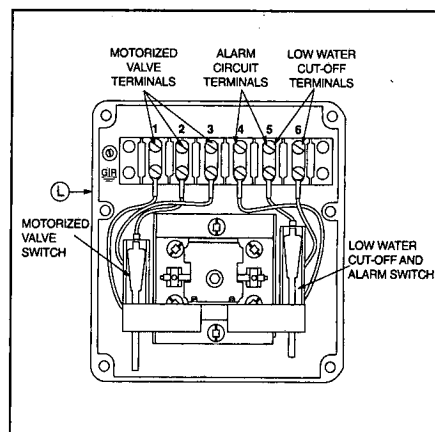

**Manual Reset
Model 158S-M**

Mercury Switches (Series 150 and 157)

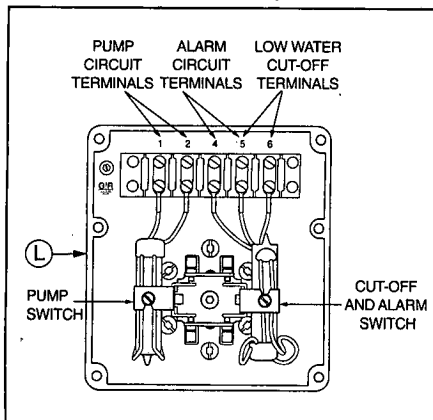

**(All models except 158
and 159)**

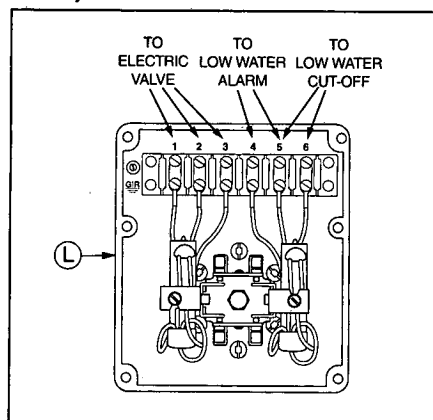

Model 158

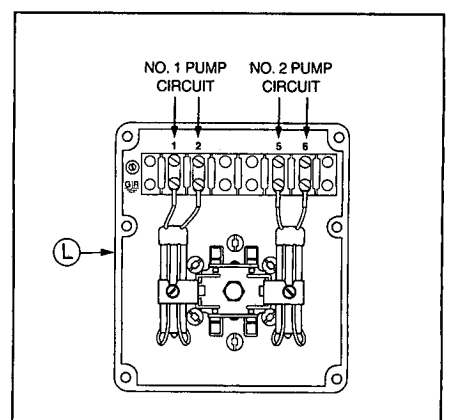

Model 159

WIRING DIAGRAMS

For Motorized Valves, refer to the valve manufacturer's wiring instructions.

Low Water Cut-Off Only

1. Main Line Switch - For burner circuits within the switch's electrical rating.

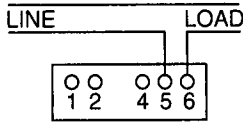

2. Pilot Switch - To holding coil of a starter when the burner circuit exceeds the switch's electrical rating.

OR

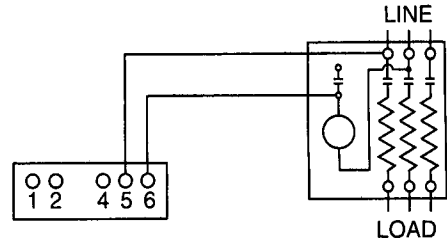

Pump Control Only

1. Main Line Switch - For pump motors within the switch's electrical rating.

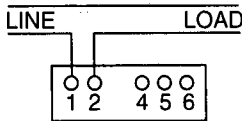

2. Pilot Switch - To holding coil of a starter when the pump circuit exceeds the switch's electrical rating.

OR

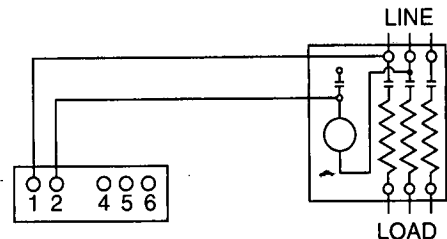

Note: For Models 159 and 159S, use terminals 5 and 6 for pump #2.

Alarm Circuit Only

1. Low Water Alarm

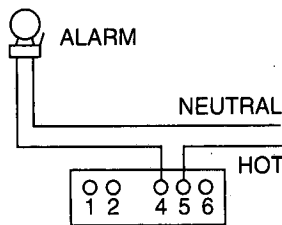

2. High Water Alarm

OR

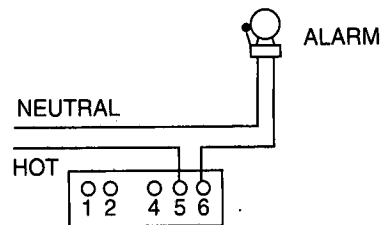

Combination Pump Control, Low Water Cut-Off and Alarm

1. Main Line Switch - For burner circuits within the switch's electrical rating.

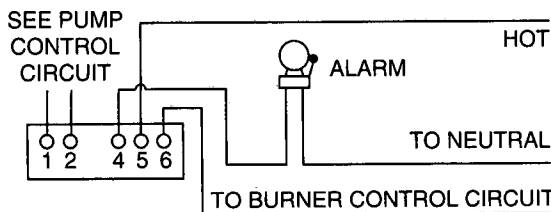

2. Pilot Switch - To holding coil of a starter when the burner circuit exceeds the switch's electrical rating.

OR

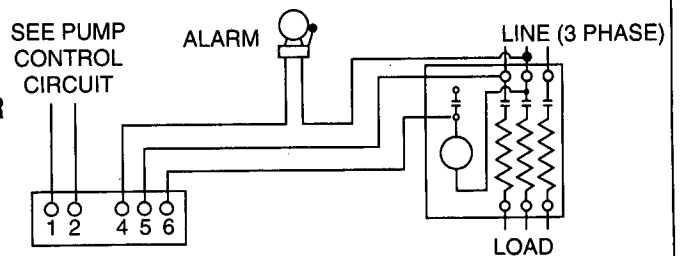

c. Re-attach the junction box cover (K).

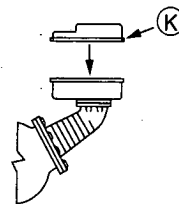

STEP 5 - Testing

This control is factory calibrated for specific applications. The following testing procedure is only meant to serve as a verification of proper operating sequence.

Dimensions provided are typical for a boiler not being fired and/or not at pressure. Actual operating ranges are shown on page 2 in the "Operation" section.

IMPORTANT: Follow the boiler manufacturer's start-up and operating instructions along with all applicable codes and ordinances. **Note:** Water levels stated below are only for 150 psi (10.5 kg/cm²) operation.

a. Turn on the electric power to the boiler. With the boiler empty the pump should go on and the burner must remain off.

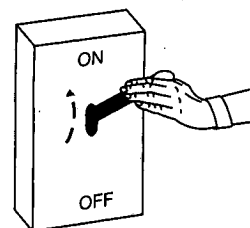

WARNING



If the burner comes on, immediately turn the boiler off and make the necessary corrections.



Failure to follow this warning could cause an explosion or fire and result in property damage, personal injury or death.

b. The boiler should begin to fill with water. Watch the gauge glass (J) until the water level reaches approximately $\frac{7}{8}$ " (22mm) above the horizontal cast line (M) on the low water cut-off.

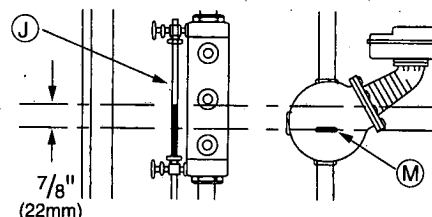

IMPORTANT: If water does not start filling the boiler, immediately turn off the the boiler and make the necessary corrections.

c. **For automatic reset models only.** When the water level reaches approximately $\frac{7}{8}$ " (22mm) above the horizontal cast line (lower for MD models) the burner should come on (pump #2 should shut off with Models 159 and 159S).

OR

For manual reset models only. When the water level reaches approximately $\frac{7}{8}$ " (22mm) above the horizontal cast line press the reset button (N). The burner should then come on.

Snap Switch Models

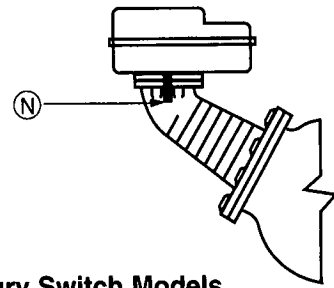

Mercury Switch Models

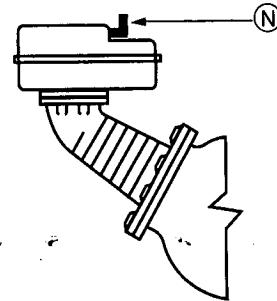

d. Continue watching the gauge glass (J) to see that the water continues to rise to approximately $1\frac{3}{8}$ " (35mm) ($1\frac{7}{16}$ " (37mm) for MD models) above the horizontal cast line (M). The pump should shut off (the motorized valve should close with Models 158 and 158S, or with Models 159 and 159S, pump #1 should shut off).

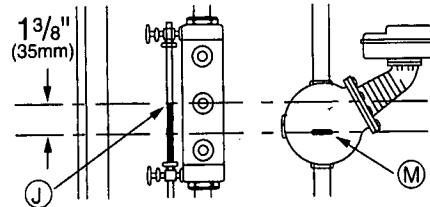

e.

CAUTION



To prevent serious personal injury from steam pipe blow down, connect a pipe to avoid exposure to steam discharge.

Failure to follow this caution could cause personal injury.

When the water level is at its normal level and the burner is on. **Slowly** open the blow down valve (G) until it is fully open. Watch the gauge glass (H) to see that the water level drops. Close the valve after verifying that the pump comes on and the burner shuts off. For Models 158 and 158S, close the blow down valve after the motorized valve opens and the burner shuts off. For Models 159 and 159S, close the blow down valve after both pumps come on. If this does not occur, immediately shut off the boiler and correct the problem and retest.

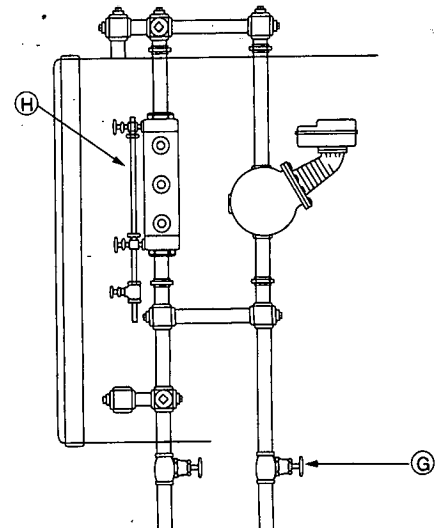

INSTALLATION COMPLETE

MAINTENANCE

SCHEDULE:

- Blow down control as follows when boiler is in operation.
 - Daily if operating pressure is above 15 psi.
 - Weekly if operating pressure is below 15 psi.

NOTE

More frequent blow-down may be necessary due to dirty boiler water and/or local codes.

- Disassemble and inspect annually. Replace the low water cut-off/pump controller if it is worn, corroded, or if components no longer operate properly.
- Inspect the float chamber and equalizing piping annually. Remove all sediment and debris.
- Replace head mechanism every 5 years. More frequent replacement may be required when severe conditions exist such as rapid switch cycling, surging water levels, and use of water treatment chemicals.
- We recommend head mechanism replacement when the switch(es) no longer operate properly. If you choose to replace the switch(es), order the proper McDonnell & Miller replacement switch or switch assembly and follow the Repair Procedure provided.

PROCEDURE:

CAUTION



To prevent serious personal injury from steam pipe blow down, connect a drain pipe to the control opening to avoid exposure to steam discharge.

Failure to follow this caution could cause personal injury.

1. Blow down the low water cut-off when the water level is at its normal level and the burner is on. **Slowly** open the blow down valve until it is fully open and observe the water level fall in the gauge glass. Close the valve after verifying that the pump contacts have closed and the burner shuts off. For Models 158 and 158S, close the blow down valve after the motorized valve opens and the burner shuts off. For Models 159 and 159S, close the blow down valve after both pumps come on. If this does not happen, immediately shut off the boiler and correct the problem.

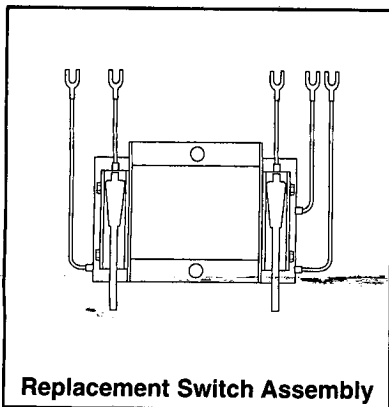

Replacement Switch Assembly

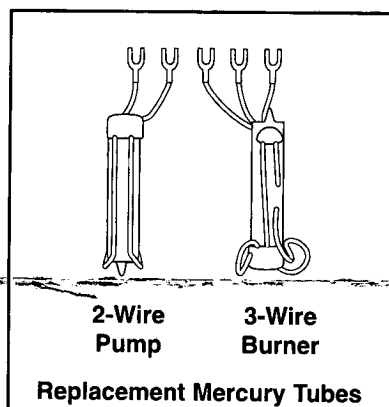

Replacement Mercury Tubes

CAUTION

Snap switches must be replaced as an assembly.

McDonnell & Miller



ITT Industries
Engineered for life

3500 N. Spaulding Avenue
Chicago, Illinois 60618
tel: 773 267-1600
fax: 773 267-0991
www.mcdonnellmiller.com

©2001 ITT Industries Inc.
Printed in U.S.A. 4-01 210341