

Barton™

FCX-Alle Transmitters

Type FHC, FHG

User Manual

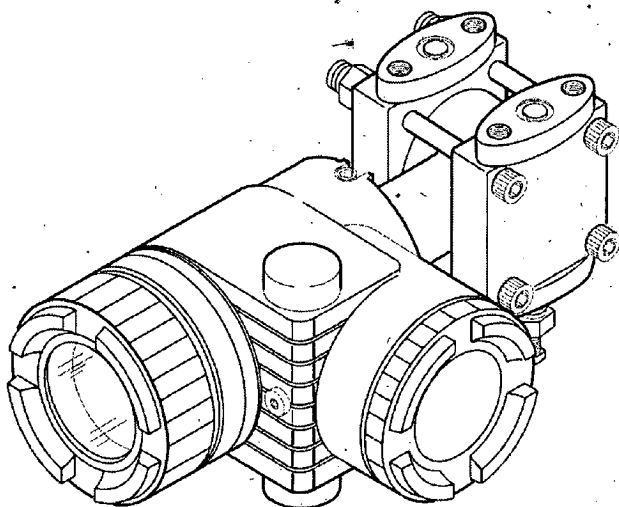

© 2004 NuFlo Technologies, Inc. All information contained in this publication is confidential and proprietary property of NuFlo Technologies, Inc. Any reproduction or use of these instructions, drawings, or photographs without the express written permission of an officer of NuFlo Technologies, Inc. is forbidden.

All Rights Reserved.
Printed in the United States of America.

Manual No. 20165004A
March 2004

INTRODUCTION



Thank you for your purchase of the NuFlo FCX-Allie Series Transmitter. This instruction manual covers version 4 of the FCX series and contains information about the installation, piping, wiring, operation and maintenance of two types of FCX-Allie transmitters.

- Read this instruction manual carefully before attempting to install, operate, or perform maintenance on the FCX-Allie Series transmitter.
- The specifications of the transmitter may be changed without prior notice for further product improvement.
- Modification of the transmitter without permission is strictly prohibited. NuFlo will not bear any responsibility for such modification.
- This instruction manual should be retained by the user of the transmitter.
- Store this manual in an easily accessible location.

CAUTION ON SAFETY



First of all, read this "Caution on Safety" to ensure correct operation of the transmitter.

- The cautionary descriptions listed here contain important information about safety, so they should be observed without fail. Those safety precautions are classified into ranks "DANGER" and "CAUTION".

 DANGER	Wrong handling may cause a dangerous situation, in which there is a risk of death or heavy injury.
 CAUTION	Wrong handling may invite a dangerous situation, in which there is a possibility of medium-level trouble or slight injury or only physical damage is predictable.

On items listed under " CAUTION", they may also lead to serious accidents depending on circumstances, and must be fully observed.

- The signs of prohibition and indication are explained in the following.

 PROHIBITION	General items which pertain to prohibition (DO NOT)
 INDICATION	General items which pertain to user's action

Installation and Piping

DANGER

- Non-explosion-proof transmitter must not be used in a place with explosive gases to prevent serious accidents such as explosion, fire, etc.

CAUTION

- The transmitter is heavy. Be careful when handling it.
- The transmitter should be installed in a place that meets the operating conditions shown in DS sheet or this instruction manual.
- Install the transmitter according to the instruction manual. Improper installation may lead to the cause of fall, trouble or incorrect operation.
- When installing, make sure that the transmitter interior is free from cable chips and other foreign objects to prevent fire, trouble, or incorrect operation.
- When power is ON, do not change the position of the field indicator in an explosion-proof area.
- When power is ON, do not change the position of the transmission unit in an explosion-proof area.
- When power is ON, do not change the angle of the indicator.
- Main valve used for piping should be selected with the maximum pressure of the process taken into account (piping parts such as main valve, etc. should be furnished by user). If the main valve and other parts do not meet the rating, it may result in leakage of gas or liquid which could lead to hazard.
- Pressure pipes to be used must meet the temperature/pressure rating.

Wiring



DANGER

- On explosion-proof type transmitter, its wiring work must be performed according to the required laws and regulations. Incorrect wiring may cause explosion, fire or other serious accidents.



CAUTION

- Before making wiring work, be sure to turn OFF the main power to prevent electric shocks.
- Use wiring materials of correct rating to prevent fire accidents.
- Connect a power source of correct rating to prevent fire accidents.
- The transmitter should be grounded as specified to prevent electric shocks or incorrect operation.
- After installing the transmitter, firmly close the covers of the transmission unit and terminal box. If not, rain water enter the transmitter which may result in trouble or incorrect operation.

Adjustment



DANGER

- When using a flame-proof transmitter, do not connect HHC to the transmitter terminals and junction terminals.

Replacement of Maintenance Parts



DANGER

- When removing an explosion-proof transmitter, turn OFF the main power, then disconnect the piping and wiring. Do not remove it when the power is ON to prevent serious accident such as explosion, fire, etc.

CAUTIONS ON USE

Be sure to observe the following instructions

Storage for a long period

Store the transmitter in a dry room at normal temperature and humidity.
Keep protection caps in place at the conduit connection and process connection.

For installation, select an appropriate place

Site at location with minimal vibration, dust and corrosive gas

At a place allowing an adequate space for checkup

Site at location large enough to allow maintenance and checking.

Mounting angle

Mount to a pipe horizontally or vertically.

Attention to overload

Do not apply a pressure outside the specified range.

Other

Besides the above, be sure to observe the cautions given in this manual.

CONTENTS

INTRODUCTION	i
CAUTION ON SAFETY	ii
CAUTIONS ON USE	iv
CONTENTS	v
1. OUTLINE	1
2. OPERATING PARTS AND THEIR FUNCTIONS	2
3. OPERATION AND SHUTDOWN	4
3.1 Preparation for operation	4
3.2 Operation	5
3.3 Shutdown	6
4. ADJUSTMENT	8
4.1 Remote Adjustments	8
4.2 Zero and span on transmitter	9
4.3 Adjustment procedure with LCD display	12
5. MAINTENANCE	13
5.1 Periodic inspection	13
5.2 Troubleshooting	14
5.3 Replacement of parts	15
5.4 Adjustment after replacement of unit	21
6. INSTALLATION AND PIPING	22
6.1 Installation	22
6.2 Piping.....	26
6.2.1 Piping of differential pressure (flow) transmitters (type: FHC).....	26
6.2.2 Piping of pressure and absolute pressure transmitters (type: FHG)	30
7. WIRING.....	32
7.1 Wiring procedure.....	32
7.2 Power voltage and load resistance	34
7.3 Grounding	35
8. SPARE PARTS.....	36
A1 BUILT-IN ARRESTER.....	39
A2 CALIBRATION	41
A3 PARAMETER SETTING PRIOR TO DELIVERY.....	44
A4 HAZARDOUS LOCATION INSTALLATION INFORMATION.....	45

1. OUTLINE

The FCX-IIIe series transmitter detects the differential pressure or pressure of various fluids, converts it into a current signal of 4 to 20mA DC and transmits it. The transmitter simultaneously provides the process signal and various diagnostic information in both a HART and Proprietary serial format. The serial data is superimposed on the 4 to 20 mA signal.

Transmitter settings (such as range and damping time constant, etc.) can be changed from an HHC (HandHeld Communicator).

Principle

The operating principle of the FCX-IIIe series transmitter is shown in the block diagram below. The input pressure is changed into an electrostatic capacitance in the detecting unit. The capacitance output, which is proportional to the differential pressure input, undergoes conditioning and amplification in the transmission unit and is then output as a current of 4 to 20mA.

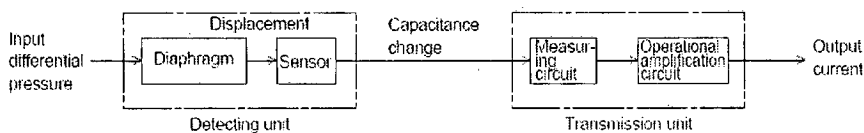

2. OPERATING PARTS AND THEIR FUNCTIONS

FCX-AIIe Series transmitter

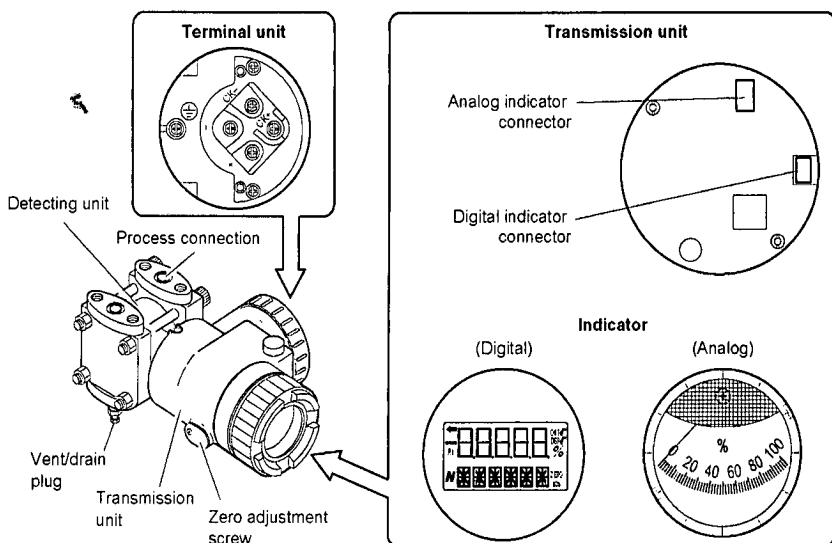

Description of FCX-AIIe Series transmitter

Part name	Description
Detecting unit	Detects pressure, differential pressure or level of fluid.
Transmission unit	Converts the detected signal into an output signal.
Vent/drain plug	Used for gas discharge or draining. (Attention should be paid under a high pressure.)
Process connection	Connects impulse pipes from the process.
Conduit connection	Connects the output cable.
Zero adjustment screw	Adjusts zero (Refer to Section 7.)

Transmission unit

Part name	Description
Analog indicator connector	Used for connecting an analog indicator.
Digital indicator connector	Used for connecting a digital indicator.
Indicator (option)	Analog or digital indicator, available.

Terminals

Symbol	Description
+, -	Connects the output cable.
CK+, CK-	Used for checking the output or connecting an indicator.
	An external terminal used for grounding.

Mode indicating function of digital indicator

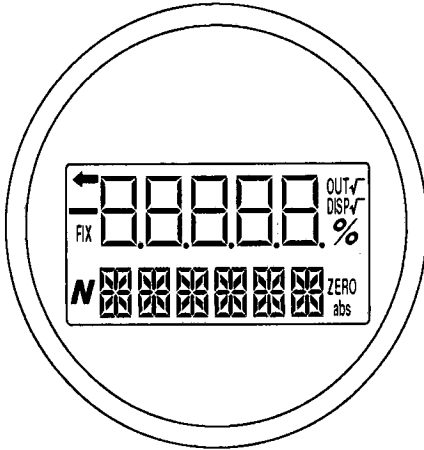

Mode indication

Mode	When indicated	When not indicated
%	% output	Actual scale
ZERO	External zero adjustment possible	External zero adjustment impossible
DISP ✓	Digital indicator ✓ display	Digital indicator proportional display
OUT ✓	✓ output	Proportional output
FIX	Fixed current mode	Measurement mode
←	Sampling status (Flicker)	
abs	Absolute pressure	Gage pressure
-	Output value < Zero	Output value ≥ Zero
N	(a part of unit indicator)	

3. OPERATION AND SHUTDOWN

3.1 Preparation for operation

Before operating the transmitter, be sure to perform the following checks and procedures. On zero point check or zero adjustment in flameproof (explosion-proof) hazardous area, do not open terminal cover and do not use HHC. Use the transmitter indicator and the external adjustment screw.

Preparation procedure

- (1) Check for liquid or gas leakage from the process connection, etc. by applying soapy water or the like.
- (2) Check the signal wiring according to the "Terminalblock connection diagram" shown in 7.1.
- (3) Vent gas from the transmitter in the case of liquid measurement.

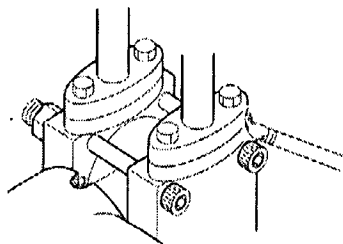

Important

When the plant requires chemical cleaning at the start of operation, be sure to close the valve of the transmitter to prevent entry of cleaning liquid into the pressure receiving unit.

- (4) Perform zero point adjustment.

Zero point check

Turn on the power to the transmitter.

Check the output signal of the transmitter by connecting a DC ammeter across CK+ and CK- of the terminal block.

After ten minutes or longer, adjust the transmitter output current to 4 mA (zero adjustment).

- (1) Adjustment by zero adjustment screw.
Adjust zero point of the transmitter to 4 mA by turning the zero adjustment screw.

Note 1) If the transmitter is locked (section 4.1), this adjustment cannot be made with the external adjustment screw.

Note 2) When a digital indicator is attached to the transmitter, make sure that the LCD lamp "ZERO" is ON.

Note 3) The adjustment screw (section 4.2) can be set to adjust span and not zero.

- (2) Adjustment by HHC
Refer to section 4.1.

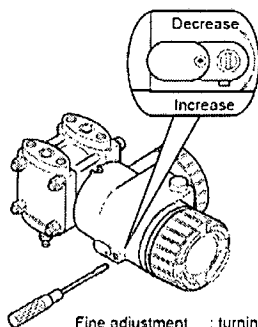

Fine adjustment : turning slowly
Rough adjustment : turning quickly



Important

1. After adjustment of the transmitter, it should be kept energized for about 10 seconds to write the adjustment results into memory.
2. Use a blade-edge screwdriver for adjusting the zero adjustment screw.

3.2 Operation

(1) Operation of pressure transmitter

Open the valve slowly to apply a pressure. When a pressure is applied, the transmitter is set in the operating status.

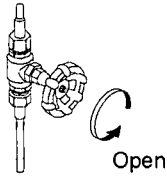

(2) Operation of differential pressure transmitter

Set the operating status by manipulating the manifold valve.

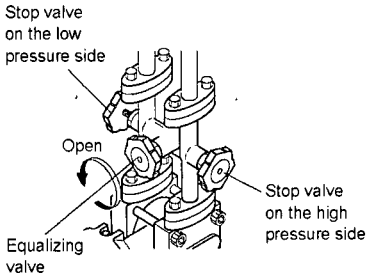

Make sure the equalizing valve is open.

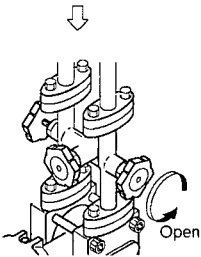

Open the stop valve on the high pressure side slowly.

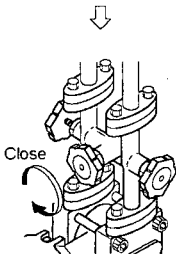

Close the equalizing valve.

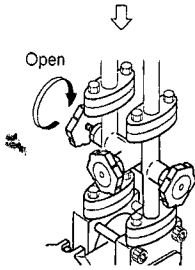

Finally, open the stop valve on the low pressure side slowly.

Check of operating status

Use a field indicator, receiving instrument or HHC to check the operating status.

3.3 Shutdown

(1) Shutdown of pressure transmitter

Close the valve slowly to stop applying a pressure. The transmitter is set in the measurement stop status.

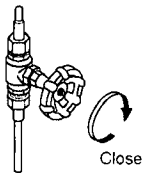

(2) Shutdown of differential pressure transmitter

Set the shutdown status by manipulating the manifold valve.

Turn off power supply.

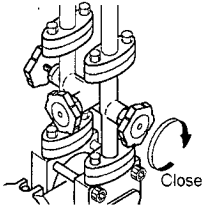

Close the stop valve on the high pressure side (H side) slowly.

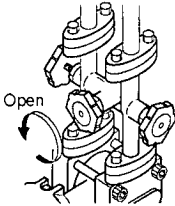

Open the equalizing valve.

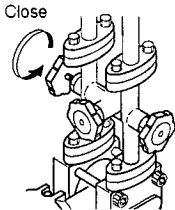

Close the stop valve on the low pressure side (L side) slowly.



Important

Before a long shutdown, discharge the process fluid and drain completely from the transmitter.

This is to protect the transmitter from freezing, corrosion, etc.

4. ADJUSTMENT

4.1 Remote adjustments

(1) Calibrations and settings in the FCX-Allc can be adjusted remotely using a variety of remote devices including

- HART-enabled PC using NuFlo-supplied software
- HART hand-held or PCs with Generic Device Descriptors
- HART hand-held or PCs using Fuji Device Descriptors
- NuFlo FXW hand-held

Each of the above interacts differently with the transmitter and provides varying capabilities. The above methods are listed in increasing capability, such that NuFlo PC software allows the adjustment of only zero, span, and dampening. By contrast, the NuFlo FXW Hand-Held allows complete manipulation of the transmitter. Additional information on the above-listed methods is available from NuFlo Measurement Systems.

4.2 Zero and span on transmitter

Changing the Measuring Range

To change the measuring range, carry out the zero adjustment before performing the span adjustment. (If zero adjustment is performed after span adjustment, the 100% point may not be adjusted correctly.)

There is no interference between zero adjustment and span adjustment.

1. Zero adjustment (change Lower Range Value internally)

(1) Set the mode setting switch to the "zero" position.

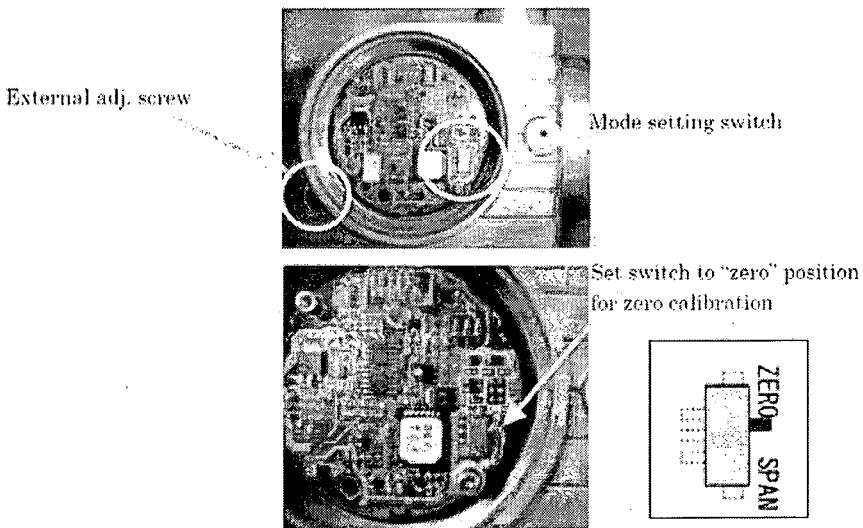

(2) Apply the standard input pressure that corresponds to the new Lower Range Value.

(3) Adjust the output signal to 4.00mA by turning the external adjustment screw.

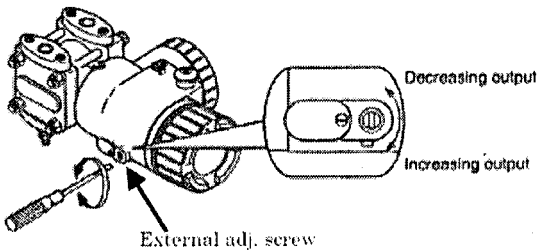

For zero suppression or elevation ranges, apply the specified LRV pressure in advance and adjust the output signal to 4.00mA using the external adjustment screw.

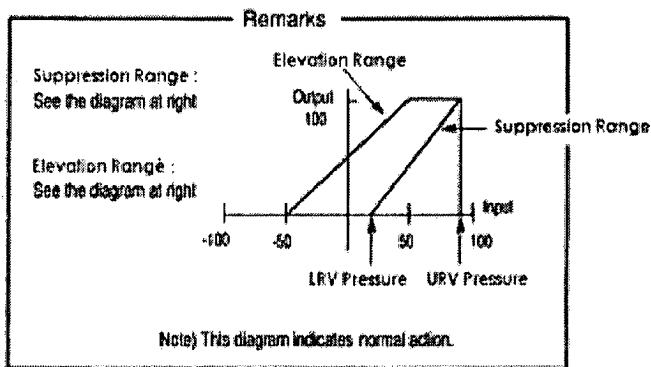

2. Span adjustment (change Upper Range Value internally)

The measuring range for each transmitter is determined by its type. To change the span, perform the following steps:

- (1) Set the mode setting switch to the "span" position.

External adj. screw

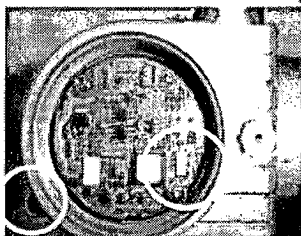

Mode setting switch

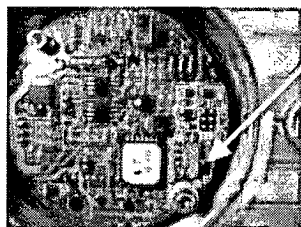

Set switch to "span" position for span calibration

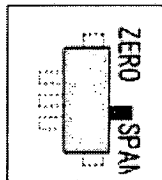

- (2) Apply the standard input pressure that corresponds with the new Upper Range Value.
- (3) Adjust the output to 20.00mA by turning the external adjustment screw.

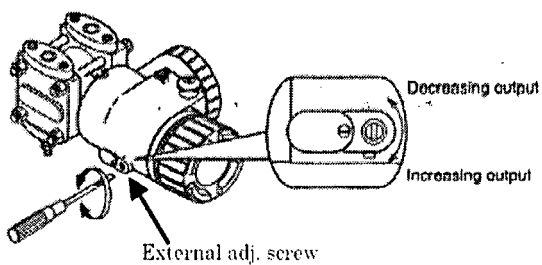

(4) Apply the input pressure that corresponds with the new Lower Range Value again and make sure the output is 4mA.

(5) Set the mode setting switch to the "zero" position before resuming normal operation.

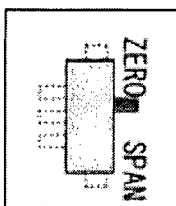

After adjustment, the transmitter should be kept energized at about 10 seconds to write the adjustment parameter into memory.

4.3 Adjustment procedure with LCD display

Outline

When local adjustment unit with LCD display (part number *ZZPFCX4-A055) is installed in the FCX-AH transmitter, some functions are available without the HHC (Hand Held Communicator).

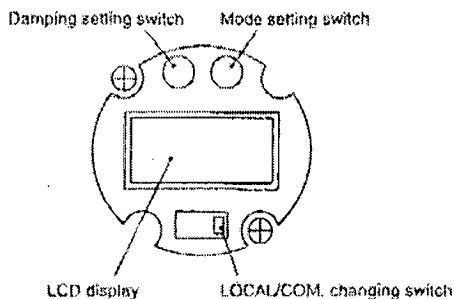

Functions of Mode setting switch

Positions of switch	Functions of external adjustment screw	Difference pressure & flow transmitter (Model FKC)	Pressure and absolute pressure transmitter (Model FKG, FKA)
0	Zero adjustment	Proportional to differential pressure	Proportional to pressure
1	Span adjustment	Proportional to differential pressure	Proportional to pressure
2	Locking of function	Proportional to differential pressure	Proportional to pressure
3	Adj. fixed current	4mA fixed current	4mA fixed current
4	Adj. fixed current	12mA fixed current	12mA fixed current
5	Adj. fixed current	20mA fixed current	20mA fixed current
6	Span adjustment	Proportional to flow	Proportional to pressure
7	Locking of function	Proportional to flow	Proportional to pressure

Functions of Damping setting switch

Positions of switch	Time constant (sec)
0	0
1	0.3
2	0.6
3	1.2
4	2.4
5	4.8
6	9.6
7	19.2

LOCAL/COMM. switch

Positions of switch	Adjustment methods
LOCAL	Adjustments of transmitter are carried out by Mode setting switch and Damping setting switch.
COMM.	Adjustments of transmitter are carried out by HHC.

5. MAINTENANCE

5.1 Periodic inspection

In order to ensure the measurement accuracy and long life of the transmitter, it is essential to inspect the transmitter periodically according to the operating conditions.

Visual inspection

Visually inspect each part of the transmitter for damage, corrosion, etc.
If you detect any material which may cause corrosion, it should be cleaned off.

Check of cover and O-ring

The transmitter has a water and dust-proof construction.
Make sure the O-ring of the case cover is not damaged or deteriorated.
Carefully prevent foreign materials from sticking to threads.

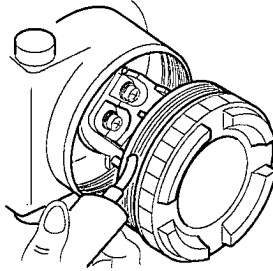

Piping leakage check

Using soapy water or the like, check the all process connections for leakage of process fluid. If necessary, drain the moisture which has accumulated in the transmitter and process pipe.

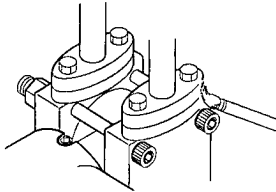

5.2 Troubleshooting

If an abnormality occurred in the process or transmitter, action should be taken with reference to the table below.

Symptom	Cause	Remedy
Output current overshoots scale (exceeds 20mA).	(1) The manifold valve does not open/close normally.	Repair the valve so that it opens/closes normally.
	(2) Pressure leak is occurring.	Repair a leak.
	(3) Process piping is improper.	Make correct piping.
	(4) Process pipe is clogged.	Eliminate the cause of clogging.
	(5) Power supply voltage and/or load resistance is improper.	Make arrangement to obtain proper values. For power supply voltage and load resistance, refer to 7.2. (For intrinsically safe installations, the power supply voltage should be 16.1 to 26V DC.)
	(6) Voltage between the external connection terminals of transmission unit is wrong.	Check for faulty cable, insulation, etc. and repair as needed. For power supply voltage and load resistance, refer to "7.2". (For intrinsically safe installations, the power supply voltage should be 16.1 to 26V DC.)
	(7) Zero and span are not adjusted.	Readjust according to chapter 4.
	(8) Electronics unit is faulty.	Replace the electronics unit according to 5.3.
No output current (less than 3.8 mA).	(1) Same as (1) to (4) above	
	(2) Power supply polarity is wrong.	Correct wiring according to 7.1.
	(3) Power supply voltage and/or load resistance is improper.	Make arrangement to obtain proper values. (For power supply voltage and load resistance, refer to 7.2.) (For intrinsically safe installations, the power supply voltage should be 16.1 to 26V DC.)
	(4) Voltage between the external connection terminals is wrong.	Check for faulty cable, insulation, etc. and repair as needed. (For power supply voltage and load resistance, refer to 7.2.) (For intrinsically safe installations, the power supply voltage should be 16.1 to 26V DC.)
	(5) Electronics unit is faulty.	Replace the electronics unit according to 5.3.
Output current error	(1) Process piping is improper.	Correct the piping.
	(2) Gas or solution is mixed in.	Vent or drain the transmitter.
	(3) Liquid density changes.	Perform density compensation.
	(4) Ambient temperature changes widely.	Minimize the temperature change.
	(5) Zero or span has deviated.	Readjust zero or span.
	(6) Electronics unit is faulty.	Replace the electronics unit according to 5.3.

If remedy is impossible, contact NuFlo Measurement Systems.

5.3 Replacement of parts

If the transmitter requires a replacement part, drain process fluid from the transmitter, disconnect it from the process and carry out replacement in an instrument room.



When removing an explosion-proof transmitter, turn OFF the main power, then disconnect the piping and wiring. Do not remove it when the power is ON to prevent serious accident such as explosion, fire, etc.

To identify faulty part

Replace the transmission unit with a spare one in order to determine whether it is the detecting unit or transmission unit which is faulty.

When the faulty unit is identified, it should be replaced with a new one.

Replacement of electronics unit

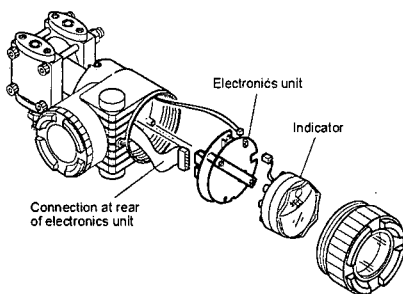

Replacing procedure

- (1) Turn off the power supply.
- (2) Remove the indicator.
- (3) Remove the electronics unit.
Unplug each connector.
- (4) Replace the electronics unit with a new one and assemble it by reversing the above procedure from (3) to (1).



When installing the electronics unit, make sure that the zero adjust screw and the volume control are positioned as shown the right.

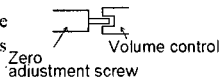

- (5) After completion of replacement, perform zero and span adjustments.



The electronics unit should be removed carefully so as not to damage the internal wiring.

Replacement of detecting unit

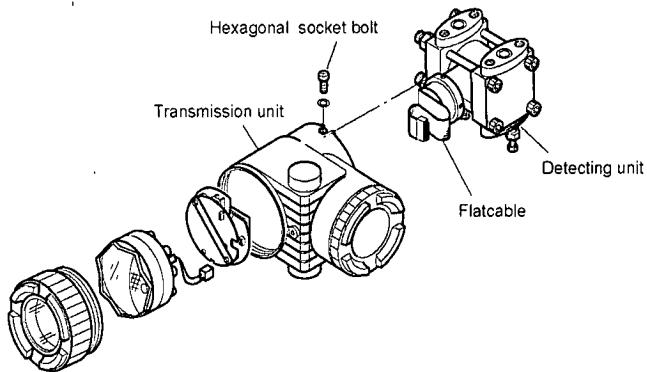

Replacing procedure

- (1) Remove the electronics unit according to "Replacement of electronics unit."
- (2) Remove the hex. socket bolts from the electronic housing.
Pull the electronics housing straight forward and away from the detecting unit.
- (3) Replace the detecting unit with a new one of the same type.
- (4) Fit the transmission unit to the detecting unit and tighten it.
- (5) Connect each connector of the electronics unit and attach it to the transmission unit.
- (6) After reassembly, carry out zero and span adjustments.



Important

- Ensure that replacement detector unit is the same specification as the original by comparing dataplates.
- When removing the transmitter case, pay attention not to damage the flatcable.

Replacement of the internal parts of detecting unit

In case of differential and flow transmitter (code symbol: FHC)

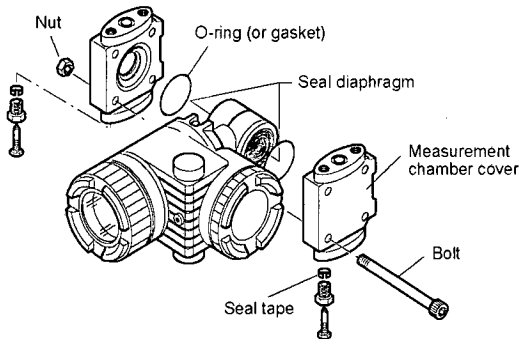

Replacing procedure

- (1) Remove four hexagon socket head bolts with a torque wrench, etc..
- (2) Disassembly gives access to the casing covers, O-rings (or gasket), hexagon socket head bolts and nuts.
- (3) After disassembly, replace the faulty part with a new one.
- (4) Before reassembly, clean the O-ring face of casing cover with the soft cloth immersed in water, alcohol, or similar detergent.
- (5) Reassemble the detecting unit by reversing the disassembling procedure. The casing covers should be assembled so as to be symmetrical with each other in the left-right direction and carefully so as not to damage the seal diaphragm. Tightening torque should follow the table below.

Bolt size	Bolt material	Tightening torque [N·m] (kgf·m) <ft·lb>	Maximum working pressure [MPa] {bar} <psi>	Application
M10	Cr-Me steel	50 (5) <36>	42 {420} <6000>	Working pressure 42 MPa {420 bar} <6000 psi> or less
M10	SUS304 ASTMB7M ASTM17M	30 (3) <22>	10 {100} <1400>	Working pressure 10MPa {100 bar} <1400 psi> or less
M10	SUS630	50 (5) <36>	42 {420} <6000>	Working pressure 42 MPa {420 bar} <6000 psi> or less

- (6) After assembly, carry out a pressure test. Apply a pressure equal to 150% of the maximum working pressure to both high pressure (H) and low pressure (L) measurement chambers of the transmitter simultaneously for 15 minutes, and make sure there is no leakage.

In case of absolute pressure and gauge pressure transmitter (code symbol: FHG)

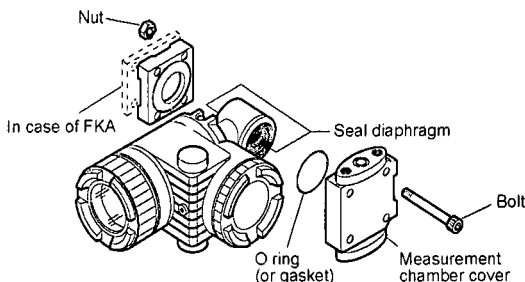

- (1) Remove four bolts with a torque wrench, etc..
- (2) Disassembly gives access to casing covers, O-rings (or gasket), bolts and nuts.
- (3) After disassembly, replace the faulty part with a new one.
- (4) Before reassembly, clean the O-ring face of casing cover with the soft cloth immersed in water, alcohol, or similar detergent.
- (5) Reassemble the detecting unit by reversing the disassembling procedure. The casing covers should be assembled so as to be symmetrical with each other in the left-right direction and carefully so as not to damage the seal diaphragm. Tightening torque should follow the table below.

Bolt size	Bolt material	Tightening torque [N·m] {kgf·m} <ft·lb>	Maximum working pressure [kPa] {bar abs} <psi>	Application
M10	Cr-Mo steel	50 {5} <36>	3000 {30} <430>	Common over entire range
M10	SUS304 ASTMB7M ASTML7M	30 {3} <22>	3000 {30} <430>	

- After assembly, carry out a pressure test.
Apply a pressure equal to 150% of the maximum working pressure to the high pressure measurement chamber of the transmitter for 15 minutes, and make sure there is no leakage.

Replacement of field indicator

1. Replacement of analog indicator

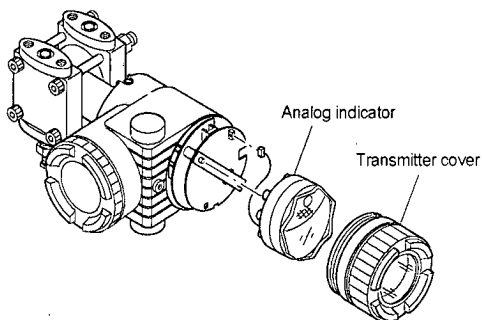

Replacing procedure

- (1) Detach the transmitter cover.
- (2) Remove the analog indicator.
- (3) Pull out the connector extending from the analog indicator.
- (4) Connect the connector of a new analog indicator to the electronics section. (See the figure below.)
- (5) Then, mount the analog indicator at the electronics section.

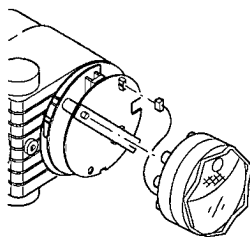

- (6) Attach the transmitter cover.

2. Replacement of digital indicator

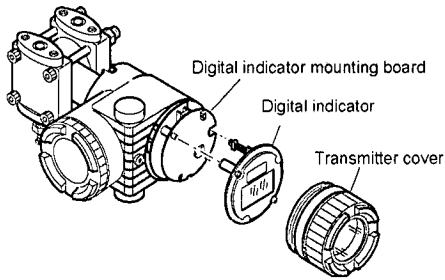

Replacing procedure

- (1) Detach the transmitter cover.
- (2) Remove two fixing screws which fasten the digital indicator and separate the indicator.
- (3) Pull out the leading end of the flatcable extending from the digital indicator after raising the slider (white knob) in the electronics section. (See the figure below.)
- (4) Insert the leading end of the flatcable of a new digital indicator into the connector plug-in port of the electronics section and fix it by pushing in the slider. Before inserting the flexible PC board, confirm its correct orientation.
- (5) Fasten the digital indicator to the electronics section by tightening two fixing screws.

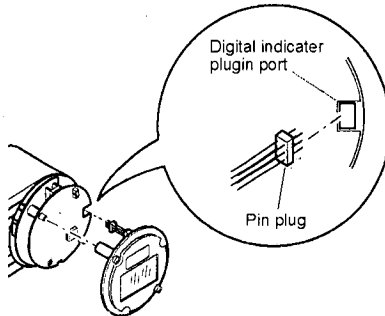

Before tightening, make sure a small recess on the surface is positioned at the top as shown below.

When twisting the flexible PC board for mounting, adequate attention should be paid not to damage the board.

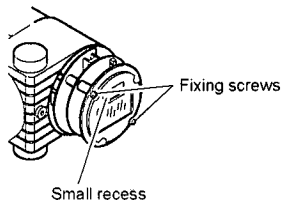

- (6) Attach the transmitter cover.

5.4 Adjustment after replacement of unit

Adjustment

After completion of the assembly work mentioned above, use the following procedures for adjustment and setting. Adjustment should be performed using the HHC.

- (1) After replacement of electronics unit (including replacement of internal parts)

Step	Adjustment item
1	Constant current output (output circuit)
2	TAG. No.
3	Type
4	Industrial value unit
5	Range (zero/span)
6	Zero/span adjustment
7	Damping
8	Output mode (LIN/
9	Burnout direction
10	Lock of adjustment function

- (2) After replacement of detecting unit (including replacement of internal parts)

Step	Adjustment item
1	Range (zero/span)

6. INSTALLATION AND PIPING

6.1 Installation

After unpacking, check the delivered items.

This transmitter can be mounted on a pipe or on a wall.

Note that the bolts (M8) for wall mounting should be supplied by the customer.

 CAUTION	<ul style="list-style-type: none">• The transmitter is heavy. Be careful when handling it.• The transmitter should be installed in a place that meets the operating conditions shown in DS sheet or instruction manual.• Install the transmitter according to the instruction manual. Improper installation may lead to the cause of fall, trouble or incorrect operation.• When installing, make sure that the transmitter interior is free from cable chips and other foreign objects to prevent fire, trouble or incorrect operation.
---	---

 DANGER	<ul style="list-style-type: none">• Non-explosion-proof transmitter must not be used in a place with explosive gas to prevent serious accidents such as explosion, fire, etc.
--	---

 Important	<p>If the transmitter is not used soon after delivery, then leave it packed and store it in a room at the normal temperature and humidity (25°C <77°F>, 60%RH).</p>
---	---

Bracket mounting

Mount the bracket to the transmitter.

The bracket should be mounted to the process cover as shown below.

(Differential pressure/flow transmitters, pressure transmitters, types: FHC, FHG)

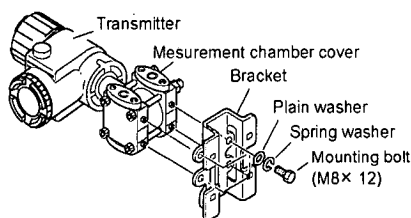

Mounting

Pipe mounting

- (1) Fasten the transmitter to a vertical or horizontal pipe using the supplied U-bolt (Tightening torque approximately 15 N·m (1.5 kgf·m) <11 ft·lb>).
- (2) Use a pipe of outside diameter $\phi 60.5 < 2.38 >$ mm.

(FHC, FHG)

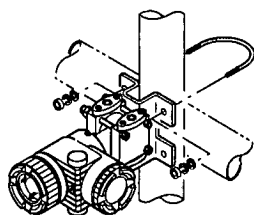

Wall mounting

- (1) Fasten to wall face by M8 bolt utilizing the U-bolt holes.

Change of field indicator position



Avoid the following procedure in an explosionproof area.

It is sometimes preferable to mount the indicator on the terminal block side due to installation location.

In such a case, the following mounting procedure should be followed for analog indicator.

Digital indicator cannot be mounted on the terminal block side.

Indicator attached to electronics unit side.

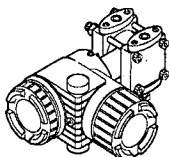

- ① Remove the cover with window and indicator.

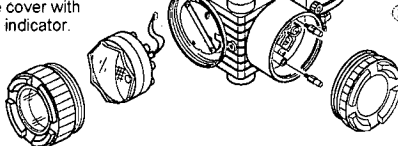

- ② Remove the cover.

- ③ Mount the supplied attachment to the pin plug.

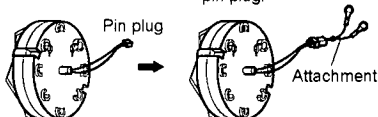

- ④ Mount the supplied studs on the terminal block.

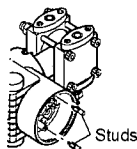

- ⑤ Attach the cover.

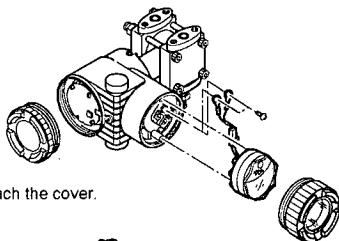

- ⑥ Connect the red wire (+) of the indicator to CK+ and the black wire (-) of the indicator to CK-, then attach the cover with window.

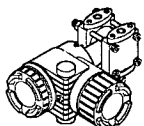

Indicator attached to terminal block side.

Change of transmission unit position



Avoid the following procedure in an explosionproof area.

Wiring is sometimes difficult depending on the installation location. In such a case, it is convenient to carry out the following.

Before turning the transmission unit, remove the electronics unit.

The transmission unit is secured by 2 hex socket bolts.

Loosen the bolts, turn the transmission unit at 90° or 180° in the clockwise or counterclockwise direction and fix it by the screws. Then, carry out wiring.



If the transmission unit has been turned excessively without removing the electronics unit, straighten the flatcable which connects the electronics unit in the transmission unit and the detecting unit, and set the transmission unit again.

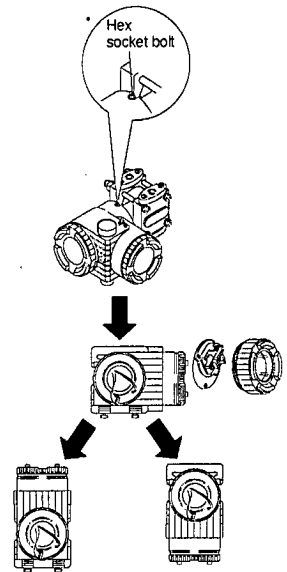

Change of indicator angle



Avoid the following procedure in an explosionproof area.

In case of an analog indicator, it can be turned $\pm 180^\circ$ in 90° increments because it is connected with a pin plug.

Digital indicator does not allow change of its mounting direction.

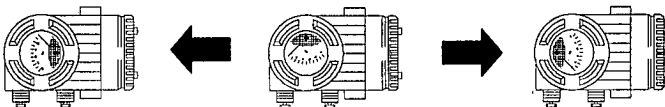

Check space

Ensure a space of about 500mm against the cover in order to facilitate check, adjustment, etc.

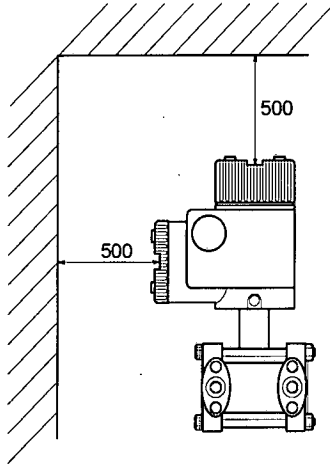

Change of vent/drain plug position

Grasp the hexagon part of vent/drain plug and rotate it to remove.

Bind vent/drain plug's thread with new seal tape and mount vent/drain plugs to new process connections.

Tightening torque : 25N·m (2.5kgf·m) <18ft·lb>

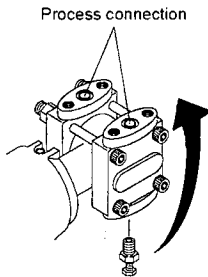

6.2 Piping

It is generally recognized that there are appropriate positioning relationship between the transmitter and main process piping for accurate measurement to avoid harmful gas or liquid accumulation. General recognitions are;

- ① Mount transmitter below main process piping for liquid or steam measurement.
- ② Mount transmitter above main process piping for gas measurement.

The standard style of FCX-All series transmitter correspond to the piping procedure ① mentioned above. Change the vent/drain plug to correspond to the piping procedure ②.



Main valve used for piping should be selected with the maximum pressure of the process taken into account (piping parts such as main valve, etc. should be furnished by user). If the main valve and other parts do not meet the rating, it may result in leakage of gas or liquid which could lead to a hazard.

6.2.1 Piping of differential pressure and flow transmitters (type: FHC.)

Check of high/low pressure sides of transmitter

The detecting unit of the differential pressure transmitter bears symbols H and L which represent high and low pressure sides, respectively.

Also, vent/drain plugs are provided at the lower process connection, while impulse pipes are connected at the upper process connections.

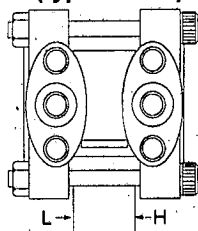

Removal of protective cap

The process connection ports of the transmitter and manifold (equalizer) valve are fitted with protective caps. Before piping, be sure to remove the caps. When removing the caps, carefully protect the threaded portion and sealing face from damage.

Connection of transmitter and impulse pipes

- (1) When using the manifold valve, it should be fixed to the transmitter by tightening four oval flange setbolts (7/16-20UNF), and then the impulse pipe should be connected to the manifold valve. Tightening torque of 7/16-20UNF mounting bolt should be 30 to 40 N·m (3 to 4 kgf·m).
- (2) If a manifold valve is not used, the impulse pipes can directly be screwed into the transmitter. If thread size does not match between the transmitter and impulse pipes, an oval flange should be used. Tightening torque of 7/16-20UNF mounting bolt in an oval flange should be 30 to 40 N·m (3 to 4 kgf·m).

Position of process taps (Horizontal main process piping)

The position of the process tap is determined by the relationship between the condition, characteristics and measuring point of the process fluid.

Note the following figures when planning and installing the piping.

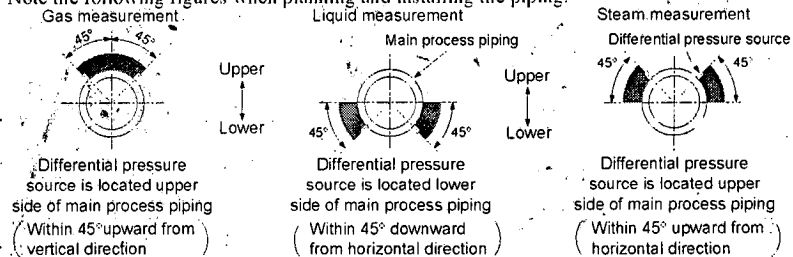

Typical examples of piping

1. Flow measurement (in case of gas)

Place the transmitter above the differential pressure source.

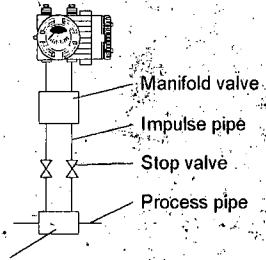

Differential pressure source (orifice)

2. Flow measurement (in case of liquid)

Place the transmitter below the differential pressure source.

Make piping so that gas in the impulse pipe is not delivered to the transmitter, and incorporate gas reservoirs as required.

Differential pressure source (orifice)

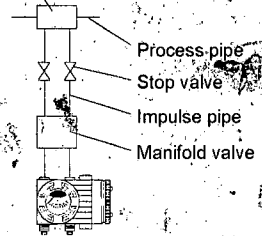

3. Flow measurement (in case of steam)

Set two condensers at the same height near the process tap. Fill the line between the condensers and transmitter with condensed water.

Install a drain port as required.

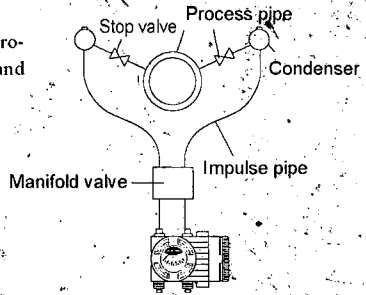

4. Pressure measurement (in case of liquid)

Zero point can be checked with a manifold valve installed.

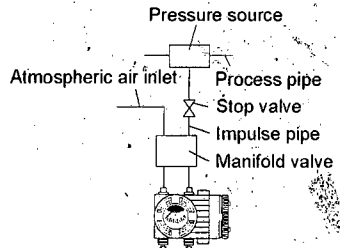

!
Important

(1) Protection is required to prevent dust from entering through the atmospheric air inlet after installation of the manifold valve.

(2) If process pressure range is narrow (below 10kPa (1000mmH₂O)), the following should be considered.

- Pressure variation due to wind around atmospheric air inlet
- Temperature variation near process taps
- Difference in atmospheric pressure between process tap and transmitter location

To overcome this, provide atmospheric pressure-side pipe with a proper orifice and consider accommodating the transmitter and atmospheric air inlet in a box.

5 Pressure measurement (in case of gas)

Mount the transmitter above the process pipes to preventing moisture from entering the inside of transmitter.

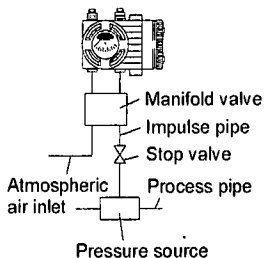

6 Level measurement

(1) In case of wet leg:

For measurement, connect the highest liquid level tapping of tank with the low pressure side of transmitter, and the lowest liquid level tapping of tank with the high pressure side of transmitter.

Level calculation formula

$$\text{LRV} : \rho H_2 - \rho_0 H_1$$

$$\text{URV} : \rho H_2 + \rho_1 h - \rho_0 H_1$$

$$\text{Span } (\Delta P) : \rho_1 h$$

LRV : Low limit of measurement (0% point)

URV : High limit of measurement (100% point)

ρ_0, ρ, ρ_1 : Density

H_1, H_2 : Liquid level, h : Liquid level change

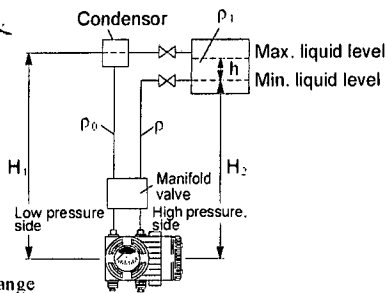

(2) In case of dry leg:

For an open tank, leave the low pressure side of transmitter open to atmosphere.

Level calculation formula

$$\text{LRV} : \rho H_1$$

$$\text{URV} : \rho H_1 + \rho_1 h$$

$$\text{Span } (\Delta P) : \rho_1 h$$

LRV : Low limit of measurement (0% point)

URV : High limit of measurement (100% point)

ρ, ρ_1 : Density

H_1 : Liquid level, h : Liquid level change

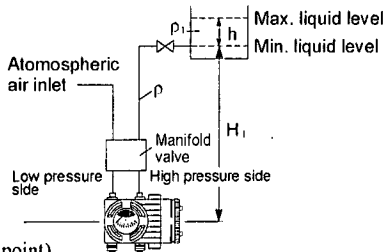

Cautions on impulse piping

- For liquid, the impulse pipes should have an upward slope of 1/10 or more between the process connection and the transmitter to prevent accumulation of gas, etc. in the detecting unit.
- For gas, the impulse pipes should have a downward slope of 1/10 or more between the process connection and transmitter to prevent accumulation of moisture, etc. in the detecting unit.
- Avoid any sharp bends in impulse pipe which may cause gas or moisture to accumulate in the impulse pipe.
- In order to prevent vibration of the transmitter body and capillary from interfering with output, the transmitter body should be installed at a vibration-free place and the capillary should be fixed to a stable support.
- Take care not to apply an excessive force to the transmitter during its connection.
- The impulse pipes used should be suitable for the working temperature, pressure, etc.
- When the measuring fluid is likely to freeze in the cover of the measurement chamber, the cover needs to be warmed up with steam or a heater.

6.2.2 Piping of pressure and absolute pressure transmitters (types: FHG)

Removal of protective cap

The process connection port of the transmitter is fitted with a protective cap. Before piping, remove the cap carefully. When removing the cap, carefully protect the threaded portion and sealing face from damage.

Connection of transmitter and impulse pipe

- Impulse pipe should be connected with an oval flange. Also, the pipe can directly be screwed into the transmitter. Tightening torque of 7.16-20UNF mounting bolt in an oval flange should be 30 to 40 N·m (3 to 4 kgf·m).
- After connection, close the stop valve of transmitter in order to prevent foreign materials from entering the inside.

Position of process taps (Horizontal main process piping)

The position of the process tap is determined by the relationship between condition, characteristics and measurement point of process fluid. Note the following figures when planning and installing the piping.

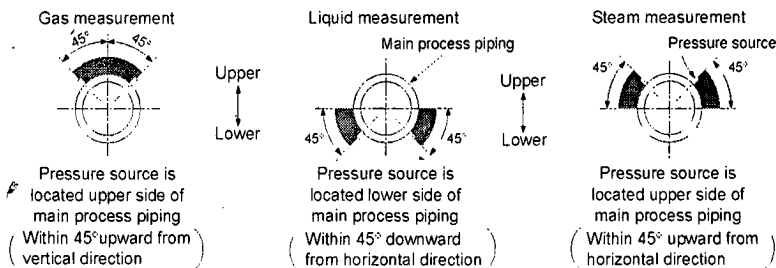

Typical examples of piping

1 Gas measurement

Place the transmitter above the pressure source.

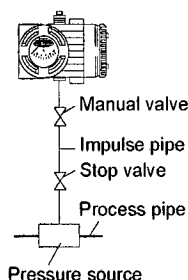

2 Liquid measurement

Place the transmitter below the pressure source.

Make piping so that gas in the process pipe is not delivered to the transmitter, and incorporate gas reservoirs as required.

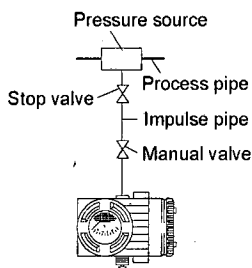

3 Steam measurement

Place the transmitter below the pressure source.

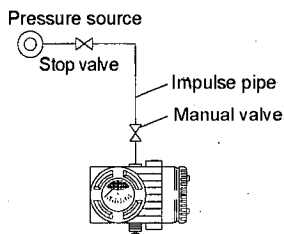

Cautions on impulse piping

- For liquid, the impulse pipe should have an upward slope of 1/10 or more between the process connection and transmitter to prevent accumulation of gas, etc. in the detecting unit.
- For gas, the impulse pipe should have a downward slope of 1/10 or more between process connection and transmitter to prevent accumulation of moisture, etc. in the detecting unit.
- Avoid any sharp bends in impulse pipe which may cause gas or moisture to accumulate in the impulse pipe.
- In order to prevent vibration of the transmitter body and capillary from interfering with output, the transmitter body should be installed at a vibration-free place and the capillary should be fixed to a stable support.
- Take care not to apply an excessive force to the transmitter during its connection.

CAUTION

The impulse pipe used should be suitable for the working temperature, pressure, etc.

- When the measuring fluid is likely to freeze in the cover of the measurement chamber, the cover needs to be warmed up with steam or a heater.

7. WIRING

Cautions on wiring

- (1) Application of a voltage exceeding 60 V DC or 40 V AC (exceeding 33 V DC or 23 V AC when arrester equipped) between “+” and “-” terminals may result in damage to the transmitter.
- (2) Use a shielded cable for the transmission line where possible.
- (3) Avoid installation of signal cable and power cable in same conduit or cable tray in order to prevent increased noise. Also, do not bring the signal cable close to large electrical equipment.



DANGER

In case of an explosionproof arrangement, wiring shall be made in accordance with the relevant regulations to ensure the explosionproofing.

7.1 Wiring procedure



CAUTION

- Before making wiring work, be sure to turn OFF the main power to prevent electric shocks.
- Use wiring materials of correct rating to prevent fire accidents.
- After installing the transmitter, firmly close the covers of the transmission unit and terminal box. If not, rain water enter the transmitter which may result in trouble or incorrect operation.

Sealing of conduit connection

Use sealing tape, if using metal pipe screw coupling or rubber gasket and fastening gland in the case of cable (outside diameter $\phi 11 < 0.43'' >$) to ensure airtightness of the connection box.



Important

1. If the connection box is located above the transmitter when using a protective tube for the wiring, then moisture may enter the protective tube and have an adverse effect on the transmitter. So maintaining airtightness of the connection box is an important practice.
2. The thread of conduit tube should meet the selected size and a seal fixture should be used.

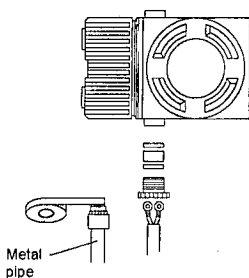

Terminal block connection diagram

Tighten the terminal screws (M4 X 10) to a torque of approximately 1.5 N·m (15 kgf·cm) <11 ft·lb> so that the wires will not loosen.

After connection, fasten the cover until it does not turn.

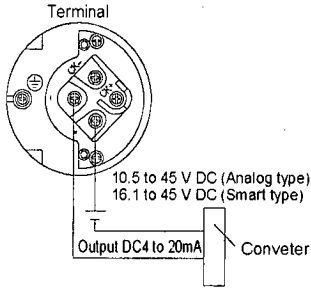

When using an external field indicator

For direct connection to an external field indicator, connect the “+” and “-” sides of the field indicator to CK+ and CK- of the transmitter as shown below.

Use an external field indicator with internal resistance of 12Ω or less.

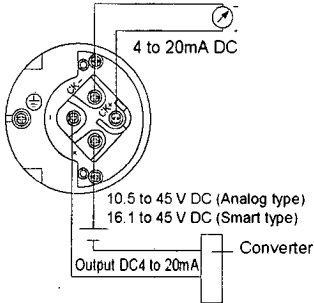

7.2 Power voltage and load resistance

Make sure the load resistance of the wiring connected to the loop is within the range shown below.



Connect power source of correct rating. Use of power source in excess of the rating may cause a fire.

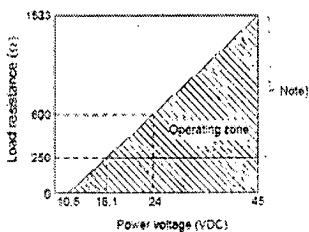

Note) For communication with HHC, minimum load resistance of 250 Ω required.

7.3 Grounding



The transmitter must be grounded. Otherwise, it may cause electric shocks or incorrect operation.

Grounding terminals are provided at two places (at the inside of terminal box and on the side of conduit connection).

By any of the methods given below, ground the transmitter in compliance with the relevant stipulation in the standard on explosionproof installation (for example, grounding resistance $100\ \Omega$ or less by one of the methods given below). In case of intrinsically safe and flameproof installation, be sure to use the ground terminal for grounding.

Grounding of transmitter casing

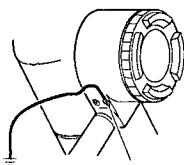

External grounding terminal

Grounding from ground terminal

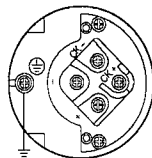

No.	Parts No.	Part Name	Q'ty	Material	Remarks
1A	*ZZPFCX4-A010	Cover	1	ADC12	Blind cover for electronics compartment.
2A	*ZZPFCX4-A021	Cover	1	ADC12	Blind cover for terminal box cover.
3A	*ZZPFCX4-A030	Cover ass'y	1	Aluminum alloy ADC12	Window cover for indicator option.
5	*ZZPFCX4-A050	Indicator kit	1		Analog. 0- 100% linear.
	*ZZPFCX4-A051	Indicator kit	1		Analog. 0- 100% square - root.
	*ZZPFCX4-A052	Indicator kit	1		Analog. dual scale.
	*ZZPFCX4-A053	Indicator kit	1		Analog. actual scale.
	*ZZPFCX4-A054	Indicator kit	1		LCD Meter.
6	*ZZPFCX4-A060	Amplifier Unit	1		Common for any FCX-A IIe models.
10	*ZZPFCX4-A101	Electronics housing	1	ADC12	With G1/2 connection. Conduit connection 1 location.
	*ZZPFCX4-A102	Electronics housing	1	ADC12	With Pg13.5 connection. Conduit connection 1 location.
	*ZZPFCX4-A103	Electronics housing	1	ADC12	With 1/2 - 14NPT connection. Conduit connection 1 location.
	*ZZPFCX4-A104	Electronics housing	1	ADC12	With M20 X 1.5 connection. Conduit connection 1 location.
11A	*ZZPFCX1-A110A	Cable gland kit	1		Requires only for IIS flameproof. G1/2 connection.
12A	*ZZPFCX4-A120A	Plug kit	1		Plug for G1/2 connection.
	*ZZPFCX4-A121A	Plug kit	1		Plug for Pg13.5 connection.
	*ZZPFCX4-A123A	Plug kit	1		Plug for M20 X 1.5 connection.
12	*ZZPFCX1-A122	Plug	1	Stainless steel	Plug for NPT 1/2 connection.
13A	*ZZPFCX4-A132	Terminal block unit	1		Round washer type.
	*ZZPFCX4-A133	Terminal block unit	1		Wire retaining washer type.
	*ZZPFCX4-A134	Terminal block unit	1		Round washer type with arrester.
	*ZZPFCX4-A135	Terminal block unit	1		Wire retaining washer type with arrester.
	20A	*ZZPFCX1-A200A	Cable gland kit		1
24A	Note) *ZZPFCX2-A241A	Fastener kit	1		Required only for BASEEFA or IIS flameproof (Exd) transmitters. Minimum order q'ty 10 pcs.
31A	*ZZPFCX1-A310A	Hex. socket screw kit	2		Minimum order q'ty 10 pcs.

4th digit of type code
S
V
W
T

No.	Parts No.	Part Name	Q'ty	Material	Remarks										
39	*ZZPFCN2-A391	Blank name plate	1	Stainless steel	Standard. Minimum order q'ty 5 pcs.										
40	*ZZPFCN1-A400	Rivet	2	Stainless steel	Minimum order q'ty 50 pcs.										
60	-----	Detecting unit	1		Contact our office for inquiry.										
61	*ZZPFCN4-B080	O - Ring	2	Viton	} Minimum order q'ty 10 pcs.										
	*ZZPFCN4-B081	Gasket	2	Teflon											
62	*ZZPFCN4-B091	Cover	2	SCS14	<table border="1"> <thead> <tr> <th>4th digit of type code</th> <th>5th digit of type code</th> </tr> </thead> <tbody> <tr> <td>A,S</td> <td>/</td> </tr> <tr> <td>B,E,T,N</td> <td>/</td> </tr> <tr> <td>V,W</td> <td>1,2,3</td> </tr> <tr> <td>V,W</td> <td>4</td> </tr> </tbody> </table>	4th digit of type code	5th digit of type code	A,S	/	B,E,T,N	/	V,W	1,2,3	V,W	4
	4th digit of type code	5th digit of type code													
	A,S	/													
	B,E,T,N	/													
V,W	1,2,3														
V,W	4														
	*ZZPFCN4-B093	Cover	2	SCS14											
	*ZZPFCN4-B095	Cover	2	SCS14											
	*ZZPFCN4-B097	Cover	2	SCS14											
64A	*ZZPFHC1-B121	Vent / drain kit	2	Stainless steel	Rc 1/4										
	*ZZPFHC1-B122	Vent / drain kit	2	Stainless steel	NPT 1/4										
66A	*ZZPFHC1-B143	Bolt / Nut kit	4	C.S.	Hexagon socket head cap screw										
	}				<table border="1"> <thead> <tr> <th>15th digit of type code</th> </tr> </thead> <tbody> <tr> <td>E,S</td> </tr> <tr> <td>F,T</td> </tr> </tbody> </table>	15th digit of type code	E,S	F,T							
15th digit of type code															
E,S															
F,T															
	*ZZPFHC1-B144	Bolt / Nut kit	4	Stainless steel											
	*ZZPFHC1-B145	Bolt / Nut kit	4	Stainless steel											
68	*ZZPFHC1-B160	O - Ring	1	Chloroprene	Minimum order q'ty 10 pcs.										
80A	*ZZPFHC1-B171	Mounting braket kit	1	Stainless steel											

A1 BUILT-IN ARRESTER

General

An arrester is used to protect a transmitter or receiver from an abnormal voltage such as lightning surges induced into signal lines. A built-in type arrester is mounted behind the terminal unit. A nameplate marked "with arrester" is attached to the terminal unit of transmitter with a built-in arrester.

Installation

The built-in arrester should be used in combination with panel mounting type arrester (type PXC) for distributor protection.

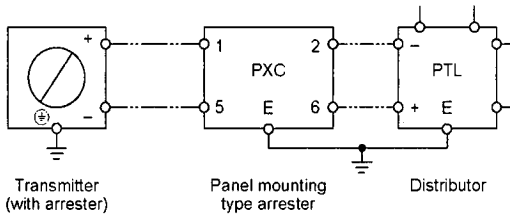

Grounding

Since transmitter and arrester groundings are internally connected together, user have only to connect the external grounding terminals to ground.

Grounding terminal must be used, in case of the explosionproof or intrinsic safety type transmitter.

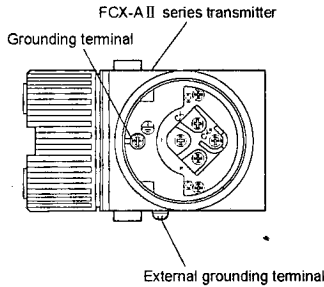

1. Grounding resistance should be 100Ω or less.
2. Avoid common grounding with a lightning rod.

Maintenance

Check of arrester

- Measure output current from the transmitter check terminals and output current to flow into transmitter (see figure below).
When current is measured with an ammeter connected to CK+ and CK- terminals, the internal resistance of the ammeter should be 12Ω or less.
- If the measured two output current are the same, the arrester is normal.
- In case the measured values have a difference of 0.1% (0.016mA) or more, the arrester is not functioning.
- In the above case, the arrester unit (terminal unit) should be replaced with a new one.

Limitation of insulation resistance and dielectric strength test

An insulation resistance and dielectric strength test should be avoided as a rule, since it may damage the arrester.

Output measurement at check terminals

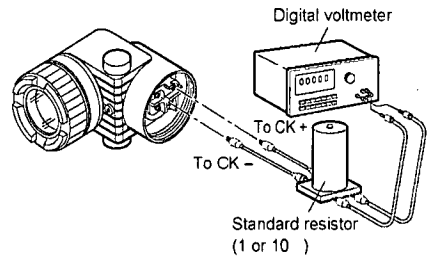

Output measurement outside transmitter

- * Disconnect the wire from the - (minus) terminal and connect the measurement device as shown below.

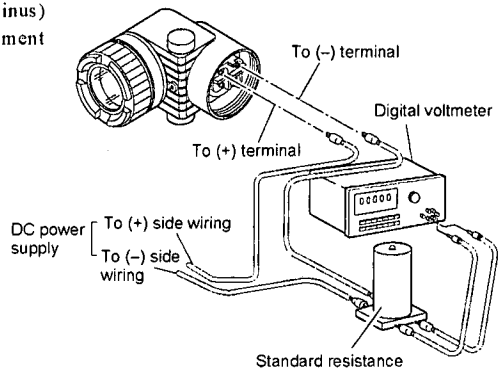

A2 CALIBRATION

Preparation for calibration

For calibration of each transmitter, the following devices are required.

- Pressure source and pressure measuring equipment (should have as high an accuracy as possible)
 - * Measurable ranges are listed in the table below.
- Power supply: DC power supply (24 V DC)
- Load resistor: 250 ohm \pm 0.0125 ohm
- Measuring device: Digital voltmeter (capable of measuring transmitter output with an accuracy better than 0.1%)
 - * Use meter having a 5-digit display.

Measurable range

Differential pressure range of FHC

Differential pressure range		
[kPa]	{mbar}	<inH ₂ O>
1.06 to 32	{10.6 to 320}	<4.166 to 125>
4.33 to 130	{43.3 to 1300}	<17.33 to 520>
16.66 to 500	{166.6 to 5000}	<2.333 to 70psi>

Pressure range of FHG

Pressure range		
[kPa]	{bar}	<Psi>
16.66 to 500	{0.16 to 5}	<2.333 to 70>
100 to 3000	{1 to 30}	<14.33 to 430>
333.3 to 10000	{3.33 to 100}	<50 to 1500>

Calibration procedure

- (1) Make wiring according to the diagram below.

Connect DC power supply (power source), digital voltmeter (measuring device), and standard resistance. When current is measured with an ammeter connected to CK+ and CK - terminals, the internal resistance of the ammeter should be 12 ohms or less.

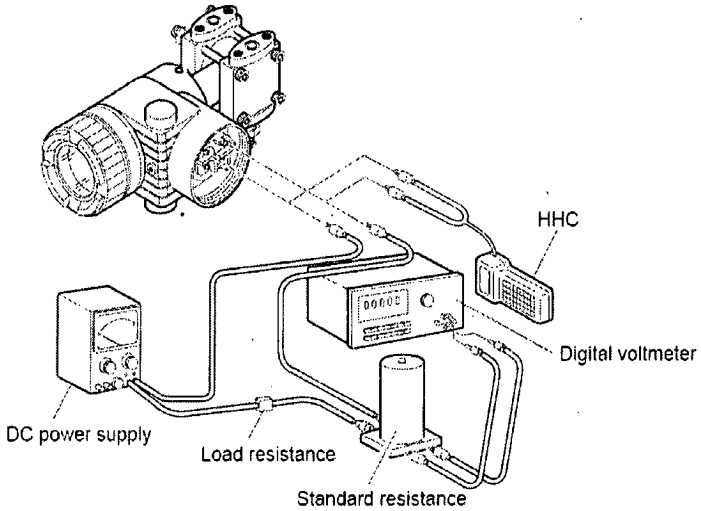

- (2) Accuracy test

Apply input pressures in the order of 0%, 25%, 50%, 75%, 100%, 75%, 50%, 25% and 0%, and read output at each input pressure.

Make sure the difference between each output value and input pressure (%) is within the accuracy rating listed in the table below.

The voltage values in the table are dependent on use of "DC power supply + standard resistor 250Ω + digital voltmeter (measuring device).

- (3) Zero/span adjustment

Adjust as required to achieve expected results.

Refer to "Zero/span adjustment" in Chapter 4.

Measurement category	Reference value	Accuracy (example)	
		Accuracy: 0.1%	Accuracy: 0.2%
Percent display (%)	0, 25, 50, 75, 100	± 0.1	± 0.2
Current measurement (mA)	4, 8, 12, 16, 20	± 0.016	± 0.032
Voltage measurement (V)	1, 2, 3, 4, 5	± 0.004	± 0.008

A3 PARAMETER SETTING PRIOR TO DELIVERY

The damping value (time constant), function of zero/span adjust screw, output current mode, indicator scale, cut point, mode below cut point and burnout, have been set prior to delivery as shown in the following. Each parameter is changed by using HHC.

No.	Item	Contents of parameter
1	Damping value (time constant)	No damping (= measuring period)
2	Zero adjust screw function	Zero point adjustment possible (Note 1)
3	Current output mode	To be set by designation when ordering (Note 2)
	Digital indicator scale (9th digit of code symbols)	To be set by designating type when ordering
4	Cut point (square-root extraction mode setting)	7.07%
5	Mode below cut point (square-root setting)	Linear
6	Burnout	To be set by designation when ordering (Note 3)
7	Linearization function	Invalid

- Note 1) For span adjustment, HHC should be used. HHC can also be used for zero adjustment.
- Note 2) In both the differential pressure transmitter (Type: FHC), the output current mode is set in linear unless it is designated.
- Note 3) Burnout direction is selectable from HHC, Hold, Over scale (20.8 to 21.6mA), under scale (3.2 to 3.8mA).

A4 HAZARDOUS LOCATION INSTALLATION INFORMATION

The A11e transmitter can be installed in compliance with CSA, FM, or ATEX agencies. In most cases, the A11e may be certified for installation via either Intrinsically Safe, Non-Incendive, or Flameproof techniques. Consult NuFlo Measurement Systems for reference documents regarding your preferred approval agency. Following are details for Intrinsically Safe installation, in accordance with factory mutual requirements.

INSTALLATION INSTRUCTIONS

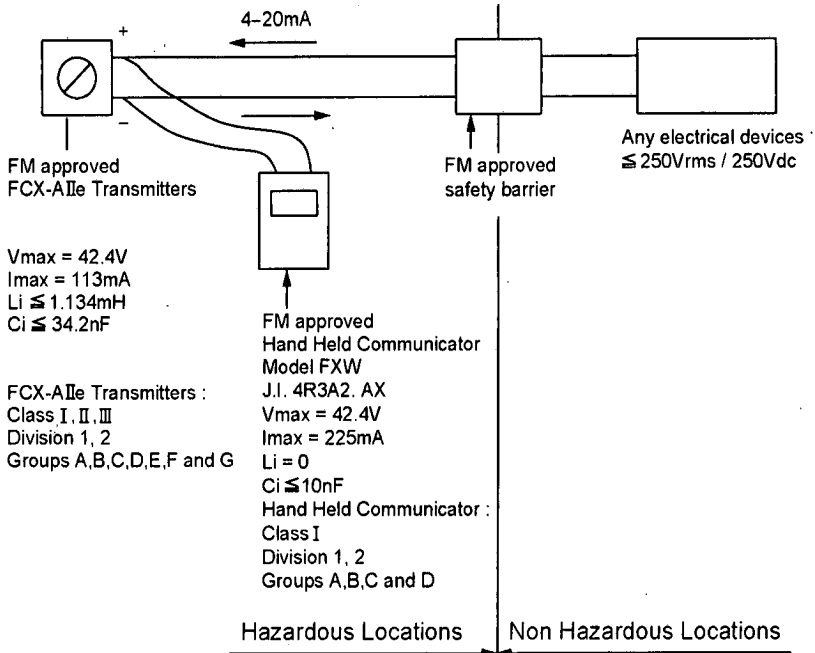

Notes:

- 1) The Intrinsic Safety Entity concept allows the interconnection of FM Approved Intrinsically safe devices with entity parameters not specifically examined in combination as a system when:
 U_o or V_{oc} or $V_l \leq V_{max}$, I_o or I_{sc} or $I_t \leq I_{max}$, C_a or $C_o \geq C_i + C_{cable}$, L_a or $L_o \geq L_i + L_{cable}$, $P_o \leq P_i$.
- 2) The Hand Held Communicator, Model FXW may be connected at any point between the transmitter and the safety barrier. Provided the hand held communicator is a FM Approved model.
- 3) Dust-tight conduit seal must be used when installed in Class II and Class III environments.
- 4) Control equipment connected to the Associated Apparatus must not use or generate more than 250Vrms or Vdc.
- 5) Installation should be in accordance with ANSI/ISA RP12.6 "Installation of Intrinsically Safe Systems for Hazardous (Classified) Locations" and the National Electrical Code ® (ANSI/NFPA 70) Sections 504 and 505.
- 6) The configuration of associated Apparatus must be Factory Mutual Research Approved under Entity Concept.
- 7) Hand Held Communicator and Associated Apparatus manufacturer's installation drawing must be followed when installing this equipment.
- 8) AEx ib is suitable only for Class I, Zone1, Hazardous (Classified) Locations and is not suitable for Class I, Zone 0, or Class I, Division 1 Hazardous (Classified) Locations.
- 9) No revision to drawing without prior Factory Mutual Research Approval.
- 10) Simple Apparatus is defined as a device that neither generates nor stores more than 1.2V, 0.1A 20uJ or 25mW.

Contents on this page are based on TC520807.

Figure 1. FCX-AIIe Series transmitter, Intrinsically Safe Installation for FM

WARRANTY - LIMITATION OF LIABILITY: Seller warrants only title to the products, software, supplies and materials and that, except as to software, the same are free from defects in workmanship and materials for a period of one (1) year from the date of delivery. Seller does not warranty that software is free from error or that software will run in an uninterrupted fashion. Seller provides all software "as is". THERE ARE NO WARRANTIES, EXPRESS OR IMPLIED, OF MERCHANTABILITY, FITNESS OR OTHERWISE WHICH EXTEND BEYOND THOSE STATED IN THE IMMEDIATELY PRECEDING SENTENCE. Seller's liability and Buyer's exclusive remedy in any case of action (whether in contract, tort, breach of warranty or otherwise) arising out of the sale or use of any products, software, supplies, or materials is expressly limited to the replacement of such products, software, supplies, or materials on their return to Seller or, at Seller's option, to the allowance to the customer of credit for the cost of such items. In no event shall Seller be liable for special, incidental, indirect, punitive or consequential damages. Seller does not warrant in any way products, software, supplies and materials not manufactured by Seller, and such will be sold only with the warranties that are given by the manufacturer thereof. Seller will pass only through to its purchaser of such items the warranty granted to it by the manufacturer.

 **NuFlo**
Measurement Systems

NuFlo Measurement Systems
14450 John F. Kennedy Blvd.
Houston, TX 77032
www.nuffotech.com

North America:

800-654-3760
281-582-9500 (Houston)
877-891-6540 (Calgary)

UK:

44-1243-826741

Singapore:

65-6737-0444