



Compact™ Individually Isolated AC/DC Relay Output Module

(Catalog Number 1769-OW8I, Series B)

Inside

Module Description	2
Module Installation.....	3
System Assembly.....	4
Mounting Expansion I/O	5
Replacing a Single Module within a System	7
Field Wiring Connections.....	8
I/O Memory Mapping	11
1769-OW8I Configuration File	12
Spare/Replacement Module Parts	13
Specifications	14
Hazardous Location Considerations	17
Environnements dangereux	17
For More Information.....	18

Module Description

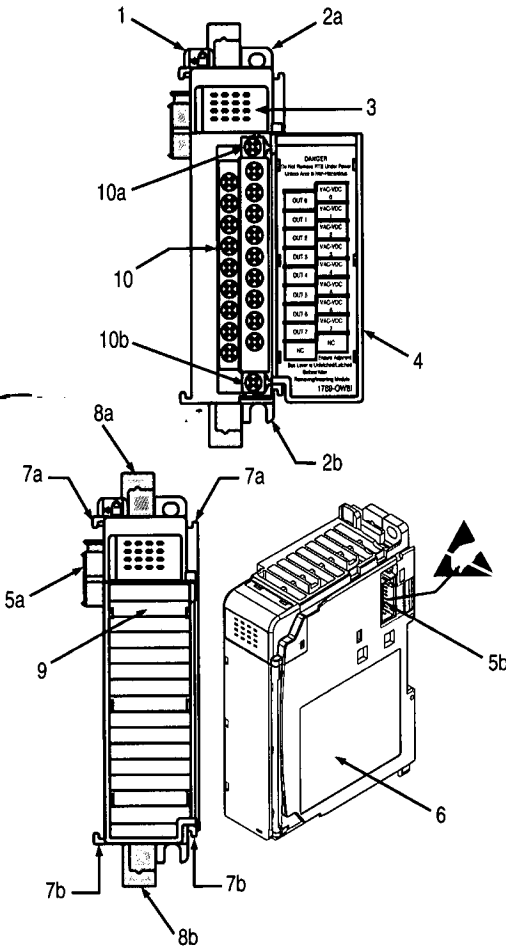

Item	Description
1	bus lever (with locking function)
2a	upper panel mounting tab
2b	lower panel mounting tab
3	I/O diagnostic LEDs
4	module door with terminal identification label
5a	movable bus connector with female pins
5b	stationary bus connector with male pins
6	nameplate label
7a	upper tongue-and-groove slots
7b	lower tongue-and-groove slots
8a	upper DIN rail latch
8b	lower DIN rail latch
9	write-on label (user ID tag)
10	removable terminal block (RTB) with finger-safe cover
10a	RTB upper retaining screw
10b	RTB lower retaining screw

Module Installation

Compact I/O is suitable for use in an industrial environment when installed in accordance with these instructions. Specifically, this equipment is intended for use in clean, dry environments (Pollution degree 2⁽¹⁾) and to circuits not exceeding Over Voltage Category II⁽²⁾ (IEC 60664-1).⁽³⁾

Prevent Electrostatic Discharge

ATTENTION



Electrostatic discharge can damage integrated circuits or semiconductors if you touch bus connector pins. Follow these guidelines when you handle the module:

- Touch a grounded object to discharge static potential.
- Wear an approved wrist-strap grounding device.
- Do not touch the bus connector or connector pins.
- Do not touch circuit components inside the module.
- If available, use a static-safe work station.
- When not in use, keep the module in its static-shield box.

Remove Power

ATTENTION



Remove power before removing or inserting this module. When you remove or insert a module with power applied, an electrical arc may occur. An electrical arc can cause personal injury or property damage by:

- sending an erroneous signal to your system's field devices, causing unintended machine motion
- causing an explosion in a hazardous environment

Electrical arcing causes excessive wear to contacts on both the module and its mating connector. Worn contacts may create electrical resistance.

(1) Pollution Degree 2 is an environment where, normally, only non-conductive pollution occurs except that occasionally a temporary conductivity caused by condensation shall be expected.

(2) Over Voltage Category II is the load level section of the electrical distribution system. At this level transient voltages are controlled and do not exceed the impulse voltage capability of the product's insulation.

(3) Pollution Degree 2 and Over Voltage Category II are International Electrotechnical Commission (IEC) designations.

System Assembly

The module can be attached to the controller or an adjacent I/O module *before* or *after* mounting. For mounting instructions, see "Panel Mounting" on page 6, or "DIN Rail Mounting" on page 7. To work with a system that is already mounted, see "Replacing a Single Module within a System" on page 7.

The following procedure shows you how to assemble the Compact I/O system.

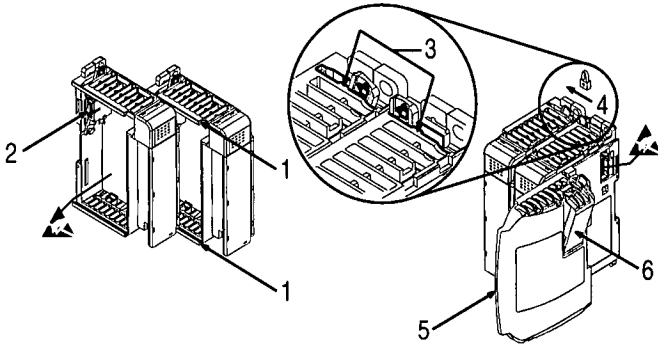

1. Disconnect power.
2. Check that the bus lever of the module to be installed is in the unlocked (fully right) position.
3. Use the upper and lower tongue-and-groove slots (1) to secure the modules together (or to a controller).
4. Move the module back along the tongue-and-groove slots until the bus connectors (2) line up with each other.
5. Push the bus lever back slightly to clear the bus locking tab (3). Use your fingers or a small screwdriver.

- To allow communication between the controller and module, move the bus lever fully to the left (4) until it clicks. Ensure it locks firmly into the bus locking tab.

ATTENTION

When attaching I/O modules, it is very important that the bus connectors are securely locked together to ensure proper electrical connection.

- Attach an end cap terminator (5) to the last module in the system by using the tongue-and-groove slots as before.
- Lock the end cap bus terminator (6).

IMPORTANT

A 1769-ECR or 1769-ECL right or left end cap must be used to terminate the end of the serial communication bus.

Mounting Expansion I/O

ATTENTION

During panel or DIN rail mounting of all devices, be sure that all debris (metal chips, wire strands, etc.) is kept from falling into the module. Debris that falls into the module could cause damage on power up.

Minimum Spacing

Maintain spacing from enclosure walls, wireways, adjacent equipment, etc. Allow 50 mm (2 in.) of space on all sides for adequate ventilation, as shown:

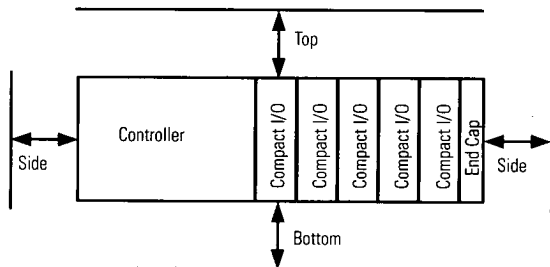

Panel Mounting

Mount the module to a panel using two screws per module. Use M4 or #8 panhead screws. Mounting screws are required on every module.

Panel Mounting Using the Dimensional Template

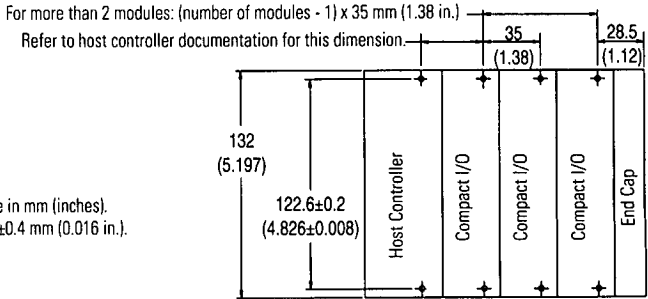

Panel Mounting Procedure Using Modules as a Template

The following procedure allows you to use the assembled modules as a template for drilling holes in the panel. If you have sophisticated panel mounting equipment, you can use the dimensional template provided on page 6. Due to module mounting hole tolerance, it is important to follow these procedures:

1. On a clean work surface, assemble no more than three modules.
2. Using the assembled modules as a template, carefully mark the center of all module-mounting holes on the panel.
3. Return the assembled modules to the clean work surface, including any previously mounted modules.
4. Drill and tap the mounting holes for the recommended M4 or #8 screw.
5. Place the modules back on the panel, and check for proper hole alignment.
6. Attach the modules to the panel using the mounting screws.

TIP



If mounting more modules, mount only the last one of this group and put the others aside. This reduces remounting time during drilling and tapping of the next group.

7. Repeat steps 1 to 6 for any remaining modules.

DIN Rail Mounting

The module can be mounted using the following DIN rails: 35 x 7.5 mm (EN 50 022 - 35 x 7.5) or 35 x 15 mm (EN 50 022 - 35 x 15).

Before mounting the module on a DIN rail, close the DIN rail latches. Press the DIN rail mounting area of the module against the DIN rail. The latches will momentarily open and lock into place.

Replacing a Single Module within a System

The module can be replaced while the system is mounted to a panel (or DIN rail). Follow these steps in order:

1. Remove power. See important note on page 3.
2. On the module to be removed, remove the upper and lower mounting screws from the module (or open the DIN latches using a flat-blade or phillips style screwdriver).
3. Move the bus lever to the right to disconnect (unlock) the bus.
4. On the right-side adjacent module, move its bus lever to the right (unlock) to disconnect it from the module to be removed.
5. Gently slide the disconnected module forward. If you feel excessive resistance, check that the module has been disconnected from the bus, and that both mounting screws have been removed (or DIN latches opened).

TIP

It may be necessary to rock the module slightly from front to back to remove it, or, in a panel-mounted system, to loosen the screws of adjacent modules.

6. Before installing the replacement module, be sure that the bus lever on the module to be installed, and on the right-side adjacent module are in the unlocked (fully right) position.
7. Slide the replacement module into the open slot.
8. Connect the modules together by locking (fully left) the bus levers on the replacement module and the right-side adjacent module.
9. Replace the mounting screws (or snap the module onto the DIN rail).

Field Wiring Connections

Grounding the Module

This product is intended to be mounted to a well-grounded mounting surface such as a metal panel. Additional grounding connections from the module's mounting tabs or DIN rail (if used), are not required unless the mounting surface cannot be grounded. Refer to *Industrial Automation Wiring and Grounding Guidelines*, Allen-Bradley publication 1770-4.1, for additional information.

Output Wiring

Basic wiring⁽¹⁾ of output devices to the 1769-OW8I is shown below.

ATTENTION



Be careful when stripping wires. Wire fragments that fall into a module could cause damage at power up. Once wiring is complete, ensure the module is free of all metal fragments.

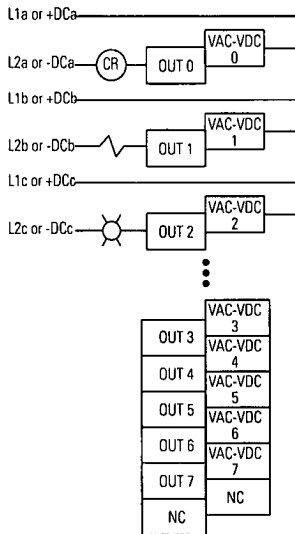

(1) **Surge Suppression** - Connecting surge suppressors across your external inductive load will extend the life of the relay contacts. For additional details, refer to *Industrial Automation Wiring and Grounding Guidelines*, Allen-Bradley publication 1770-4.1.

A removable, write-on label is provided with the module. Remove the label from the door, mark the identification of each terminal with permanent ink, and slide the label back into the door. Your markings (ID tag) will be visible when the module door is closed.

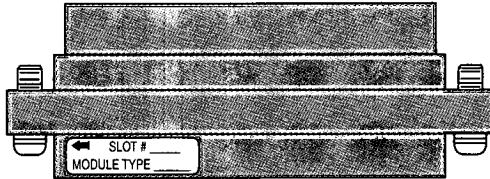

Removing the Finger-Safe Terminal Block

When wiring field devices to the module, it is not necessary to remove the terminal block. If you remove the terminal block, use the write-on label on the side of the terminal block to identify the module slot location and type.

To remove the terminal block, loosen the upper and lower retaining screws. The terminal block will back away from the module as you remove the screws. When replacing the terminal block, torque the retaining screws to 0.46 Nm (4.1 in-lbs).

Wiring the Finger-Safe Terminal Block

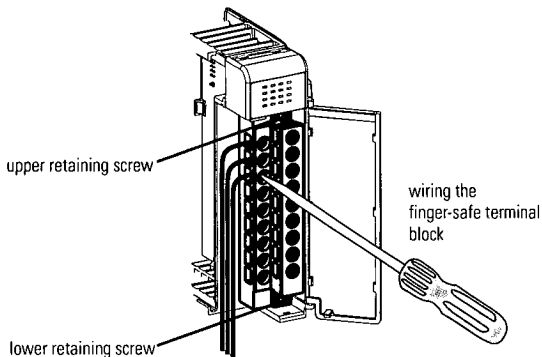

When wiring the terminal block, keep the finger-safe cover in place.

1. Loosen the terminal screws to be wired.

- Route the wire under the terminal pressure plate. You can use the bare wire or a spade lug. The terminals will accept a 6.35 mm (0.25 in.) spade lug.

TIP



The terminal screws are non-captive. Therefore, it is possible to use a ring lug [maximum 1/4 inch o.d. with a 0.139 inch minimum i.d. (M3.5)] with the module.

- Tighten the terminal screw making sure the pressure plate secures the wire. Recommended torque when tightening terminal screws is 0.68 Nm (6 in-lbs).

TIP



If you need to remove the finger-safe cover, insert a screwdriver into one of the square, wiring holes and gently pry the cover off. If you wire the terminal block with the finger-safe cover removed, you will not be able to put it back on the terminal block because the wires will be in the way.

Simplified Output Circuit Diagram

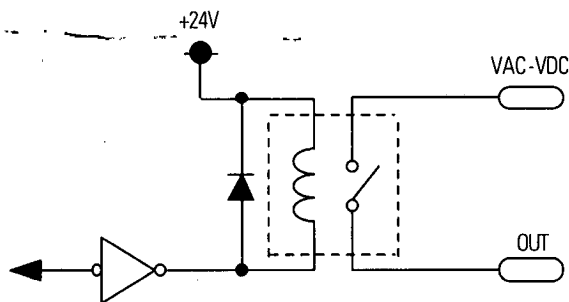

Wire Size and Terminal Screw Torque

Each terminal accepts up to two wires with the following restrictions:

Wire Type	Wire Size	Terminal Screw Torque	Retaining Screw Torque
Solid	Cu-90°C (194°F) #14 to #22 AWG	0.68 Nm (6 in-lbs)	0.46 Nm (4.1 in-lbs)
Stranded	Cu-90°C (194°F) #16 to #22 AWG	0.68 Nm (6 in-lbs)	0.46 Nm (4.1 in-lbs)

I/O Memory Mapping

Output Data File

For each module, slot x, word 0 in the output data file contains the control program's directed state of the discrete output points. For the 1769-OW8I, bits 8 to 15 are not used.

Word	Bit Position															
	15	14	13	12	11	10	9	8	7	6	5	4	3	2	1	0
0	0	0	0	0	0	0	0	0	w	w	w	w	w	w	w	w

w = write

Output Module's Input Data File

For each module, slot x, input data file word 0 contains the state of the module's output data (output data echo) file word 0. During normal operation, these input bits represent the logic state that the outputs are directed to by the control program. They are also dependent upon the:

- Program Mode configuration (if supported by the controller)
- The Fault Mode configuration (if supported by the controller)

For the 1769-OW8I, bits 8 to 15 are not used.

Word	Bit Position															
	15	14	13	12	11	10	9	8	7	6	5	4	3	2	1	0
0	0	0	0	0	0	0	0	0	r	r	r	r	r	r	r	r

r = read

IMPORTANT

The output module's input data file reflects the output data echo of the module, not the electrical state of the output terminals. It does not reflect shorted or open outputs.

It is important to use this input word if the controller adapter supports the Program Mode or Fault Mode function, and if it is configured to use them.

1769-OW8I Configuration File

The read/writable configuration data file allows the setup of the hold last state and user-defined safe state conditions.

The manipulation of the bits from this file is normally done with programming software (e.g. RSLogix 500, RSNetworkx for DeviceNet, etc.) during initial configuration of the system. In that case, graphical screens are provided via the programmer to simplify configuration. However, some systems (e.g. 1769-ADN DeviceNet Adapter) also allow the bits to be altered as part of the control program using communication rungs. In that case, it is necessary to understand the bit arrangement.

Word	Bit Position																
	15	14	13	12	11	10	9	8	7	6	5	4	3	2	1	0	
0	0	0	0	0	0	0	0	0	0	0	0	0	0	0	0	0	PFE
1	Program State for Output Array Word 0																
2	Program Value for Output Array Word 0																
3	Fault State for Output Array Word 0																
4	Fault Value for Output Array Word 0																

Program State Word

Word 1, the program state word, selects the hold last state or user-defined safe state condition for each individual output on a system transition from Run to Program.

Condition	Bit Setting
User-defined Safe State	0
Hold Last State	1

Program Value Word

The program value word, word 2, is used to program the user-defined safe state value (0=Off, 1=On). Each output is individually configurable for on or off.

Value	Bit Setting
Off	0
On	1

Fault State Word

Word 3, the fault state word, selects the hold last state or user-defined safe state condition for each individual output on a system transition from Run to Fault.

Condition	Bit Setting
User-defined Safe State	0
Hold Last State	1

Fault Value Word

The fault value word, word 4, is used to program the fault state value (0=Off, 1=On). Each output is individually configurable for on or off.

Value	Bit Setting
Off	0
On	1

Program to Fault Enable Bit (PFE)

Word 0, bit 0, allows the selection of which data value, the program or fault value, to apply to the output if a system in Program mode undergoes a system fault, resulting a change to Fault mode.

Value Applied	Bit Setting
Program	0
Fault	1

Module Default Condition

The modules default condition is all zeros, programming the conditions shown below.

Word or Bit Affected	Condition Applied
Word 0, Bit 0: Program-to-Fault Enable	Program Value
Word 1: Program State	User-defined Safe State
Word 2: Program Value	Off
Word 3: Fault State	User-defined Safe State
Word 4: Fault Value	Off

Spare/Replacement Module Parts

- Terminal Block: 1769-RTBN18 (1 per kit)
- Door Label: 1769-RL1 (2 per kit)
- Door: 1769-RD (2 per kit)

Specifications

General Specifications

Specification	Value
Dimensions	118 mm (height) x 87 mm (depth) x 35 mm (width) height including mounting tabs is 138 mm 4.65 in. (height) x 3.43 in (depth) x 1.38 in (width) height including mounting tabs is 5.43 in.
Approximate Shipping Weight (with carton)	290g (0.64 lbs.)
Storage Temperature	-40°C to +85°C (-40°F to +185°F)
Operating Temperature	0°C to +60°C (32°F to +140°F)
Operating Humidity	5% to 95% non-condensing
Operating Altitude	2000 meters (6561 feet) ⁽¹⁾
Vibration	Operating: 10 to 500 Hz, 5G, 0.030 inches maximum peak-to-peak Relay Operation: 2G
Shock	Operating: 30G panel mounted (20G DIN rail mounted) Relay Operation: 7.5G panel mounted (5G DIN rail mounted) Non-Operating: 40G panel mounted (30G DIN rail mounted)
Agency Certification	<ul style="list-style-type: none"> • C-UL certified (under CSA C22.2 No. 142) • UL 508 listed • CE and C-Tick compliant for all applicable directives
Hazardous Environment Class	Class I, Division 2, Hazardous Location, Groups A, B, C, D (UL 1604, C-UL under CSA C22.2 No. 213)
Radiated and Conducted Emissions	EN50081-2 Class A
<i>Electrical /EMC:</i>	<i>The module has passed testing at the following levels:</i>
ESD Immunity (IEC61000-4-2)	• 4kV contact, 8kV air, 4kV indirect
Radiated Immunity (IEC61000-4-3)	• 10 V/m, 80 to 1000 MHz, 80% amplitude modulation, +900 MHz keyed carrier
Fast Transient Burst (IEC61000-4-4)	• 2 kV, 5 kHz
Surge Immunity (IEC61000-4-5)	• 2 kV common mode, 1 kV differential mode
Conducted Immunity (IEC61000-4-6)	• 10V, 0.15 to 80 MHz ⁽²⁾

(1) For operation above 2000 meters, consult the factory.

(2) Conducted Immunity frequency range may be 150 kHz to 30 MHz if the Radiated Immunity frequency range is 30 MHz to 1000 MHz.

Output Specifications

Specification	1769-0W8I
Voltage Category	AC/DC normally open relay
Operating Voltage Range	5 to 265V ac 5 to 125V dc
Number of Outputs	8
Isolated Groups	8 individually isolated outputs
Bus Current Draw (max.)	125 mA at 5V dc (0.625W) 100 mA at 24V dc (2.4W)
Heat Dissipation	2.83 Total Watts (<i>The Watts per point, plus the minimum Watts, with all points energized.</i>)
Signal Delay (max.) – resistive load	turn-on = 10 ms turn-off = 10 ms
Off-State Leakage (max.)	0 mA
On-State Current (min.)	10 mA at 5V dc
Continuous Current per Point (max.)	2.5A (Also see "Relay Contact Ratings" on page 16.)
Continuous Current per Common (max.)	2.5A
Continuous Current per Module (max.)	16A
Power Supply Distance Rating	8 (The module may not be more than 8 modules away from the power supply.)
Output Point to Bus Isolation	Verified by one of the following dielectric tests: 1836V ac for 1 sec. or 2596V dc for 1 sec. 265V ac working voltage (IEC Class 2 reinforced insulation)
Isolated Groups	8: Each point individually isolated from the other.
Group to Group Isolation	Verified by one of the following dielectric tests: 1836V ac for 1 sec. or 2596V dc for 1 sec. 265V ac working voltage (basic insulation) 150V ac working voltage (IEC Class 2 reinforced insulation)
Vendor I.D. Code	1
Product Type Code	7
Product Code	87

Relay Contact Ratings

Volts (max.)	Continuous Amps per Point (max.)	Amperes ⁽¹⁾		Voltamperes		NEMA ICS 2-125
		Make	Break	Make	Break	
240V ac	2.5A	7.5A	0.75A	1800 VA	180 VA	C300
120V ac		15A	1.5A			
125V dc	1.0A	0.22A ⁽²⁾		28 VA		R150
24V dc	2.0A	1.2A ⁽²⁾		28 VA		—

- (1) **Surge Suppression** - Connecting surge suppressors across your external inductive load will extend the life of the relay contacts. For additional details, refer to Industrial Automation Wiring and Grounding Guidelines, Allen-Bradley publication 1770-4.1.
- (2) For dc voltage applications, the make/break ampere rating for relay contacts can be determined by dividing 28 VA by the applied dc voltage. For example, 28 VA/48V dc = 0.58A. For dc voltage applications less than 48V, the make/break ratings for relay contacts cannot exceed 2A.

Hazardous Location Considerations

This equipment is suitable for use in Class I, Division 2, Groups A, B, C, D or non-hazardous locations only. The following WARNING statement applies to use in hazardous locations.

WARNING



EXPLOSION HAZARD

- Substitution of components may impair suitability for Class I, Division 2.
- Do not replace components or disconnect equipment unless power has been switched off or the area is known to be non-hazardous.
- Do not connect or disconnect components unless power has been switched off or the area is known to be non-hazardous.
- This product must be installed in an enclosure.
- All wiring must comply with N.E.C. article 501-4(b).

Environnements dangereux

Cet équipement est conçu pour être utilisé dans des environnements de Classe 1, Division 2, Groupes A, B, C, D ou non dangereux. La mise en garde suivante s'applique à une utilisation dans des environnements dangereux.

AVERTISSEMENT



DANGER D'EXPLOSION

- La substitution de composants peut rendre cet équipement impropre à une utilisation en environnement de Classe 1, Division 2.
- Ne pas remplacer de composants ou déconnecter l'équipement sans s'être assuré que l'alimentation est coupée et que l'environnement est classé non dangereux.
- Ne pas connecter ou déconnecter des composants sans s'être assuré que l'alimentation est coupée ou que l'environnement est classé non dangereux.
- Ce produit doit être installé dans une armoire.

For More Information

For	Refer to this Document	Pub. No.
A more detailed description of how to install and use your Compact™ I/O with MicroLogix™ 1200 & 1500 programmable controller.	MicroLogix 1200 & 1500 Programmable Controllers User Manual	1764-UM001B-US-P
A more detailed description of how to install and use your Compact I/O with the 1769-ADN DeviceNet Adapter.	1769-ADN DeviceNet Adapter User Manual	1769-UM001A-US-P
A more detailed description of how to install and use your Compact I/O with the CompactLogix™ System.	CompactLogix System User Manual	1769-UM007C-EN-P
More information on proper wiring and grounding techniques.	Industrial Automation Wiring and Grounding Guidelines	1770-4.1

If you would like a manual, you can:

- download a free electronic version from the internet:
www.ab.com/micrologix or **www.theautomationbookstore.com**
- purchase a printed manual by:
 - contacting your local distributor or Rockwell Automation representative
 - visiting **www.theautomationbookstore.com** and placing your order
 - calling 1.800.963.9548 (USA/Canada)
or 001.330.725.1574 (Outside USA/Canada)

Compact, MicroLogix, CompactLogix, RSLogix and RSNetworx are trademarks of Rockwell Automation.
DeviceNet is a trademark of Open DeviceNet Vendor Association (ODVA).

Reach us now at www.rockwellautomation.com

Wherever you need us, Rockwell Automation brings together leading brands in industrial automation including Allen-Bradley controls, Reliance Electric power transmission products, Dodge mechanical power transmission components, and Rockwell Software. Rockwell Automation's unique, flexible approach to helping customers achieve a competitive advantage is supported by thousands of authorized partners, distributors and system integrators around the world.

Americas Headquarters, 1201 South Second Street, Milwaukee, WI 53201-2496, USA, Tel: (1) 414 382-2000, Fax: (1) 414-382-4444
European Headquarters SA/AV, Boulevard du Souverain 36, 1170 Brussels, Belgium, Tel: (32) 2 663 0600, Fax: (32) 2 663 0640
Asia Pacific Headquarters, 27/F Citicorp Centre, 18 Whitfield Road, Causeway Bay, Hong Kong, Tel: (852) 2887 4788, Fax: (852) 2508 1846

Publication 1769-IN053A-EN-P - April 2001

Supersedes Publication 1769-IN005C-EN-P - June 2000



**Rockwell
Automation**

PN 40072-116-01 (A)

© 2001 Rockwell International Corporation. Printed in Malaysia.

